

SECTIONAL VIEW – ECLIPSE Model 36X48 TYPE 5

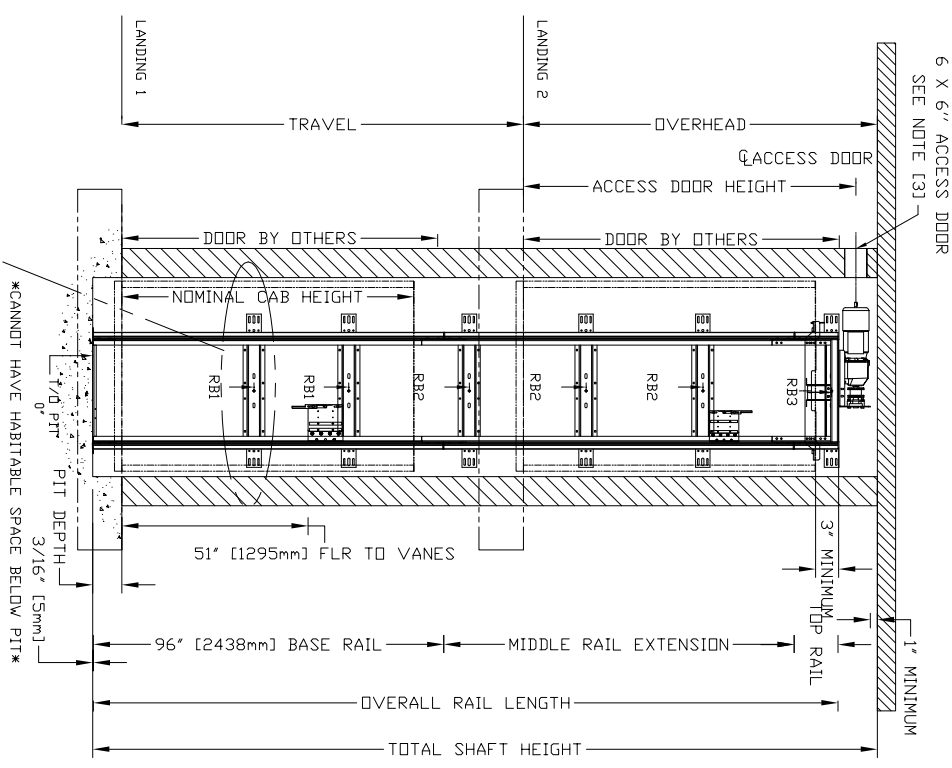

2 MOUNTING POSITIONS CENTER OR SIDE

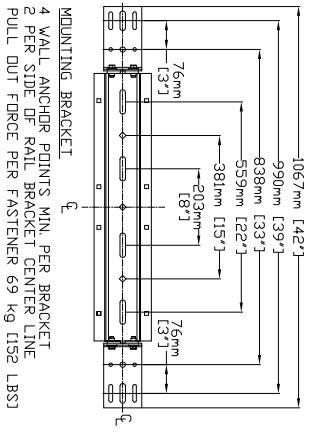

FINAL RAIL BRACKET RB3 LOCATION	BELOW THE MOTOR CONCORD REPRESENTATIVE FOR EXACT LOCATION
INTERMEDIATE RAIL BRACKET RB2	32" (813mm) INTERVALS AFTER 2nd BOTTOM BRACKET
BOTTOM RAIL BRACKET RB1	44" (1118mm) & 71" (1804mm) ABOVE PIT FLOOR

4 WALL ANCHOR POINTS MIN. PER BRACKET 2 PER SIDE OF RAIL BRACKET CENTER LINE PULL OUT FORCE PER FASTENER 69 KG (152 LBS)

HALL BUTTON NEEDED AT ALL FLOORS

DOOR SWING

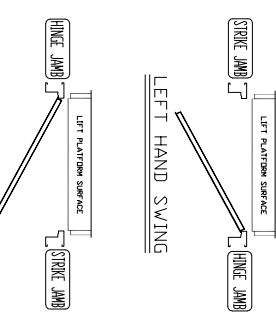
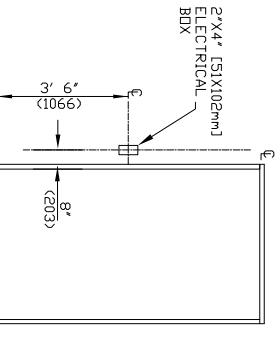

LEFT HAND SHOWN RIGHT HAND OPPOSITE

DOCUMENT REVISION 002, DATE: 12/15/08

PLAN VIEW – ECLIPSE Model 36X48 TYPE 5

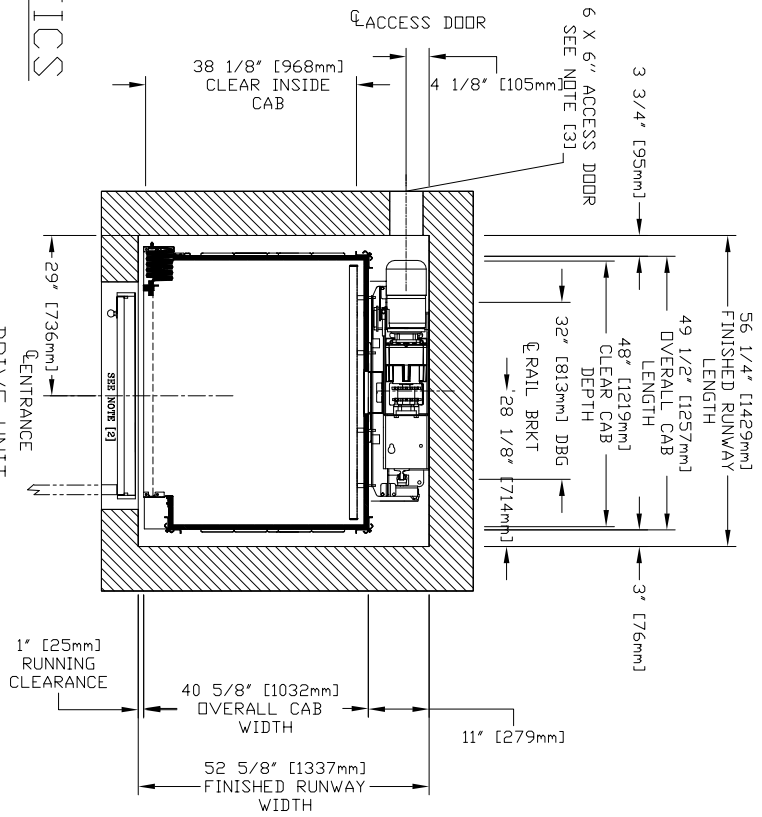

FORCES

RAIL FORCES	
*R1	*R2
1382 kg (3024 lb)	882 kg (1944 lb)
442 kg (974 lb)	442 kg (974 lb)
RAIL MASS	RAIL MASS
WEIGHT: 1160 lbs / ft	WEIGHT: 1160 lbs / ft
PIT FLOOR TO SUPPORT LOAD (INCLUDES IMPACT)	
2909 kg	
6440 lbs	

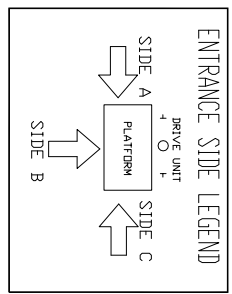

CHARACTERISTICS

GENERAL

APPLIED CODE: _____
 CAPACITY: _____ (750, 1000 LBS)
 NOMINAL SPEED: _____ 40 FPM
 TRAVEL: _____
 PIT DEPTH: _____ (MIN. 6')
CAR DETAILS
 CAB PANEL SELECTION: _____ (SEE CHART)
 CEILING SELECTION: _____ (WITH MATCH)
 CAB FLOORING: _____ (PLYW, FINISH)
 FINISHED FLOOR THICKNESS: _____ (1/8 to 3/4")
 CAB HEIGHT: _____ (80, 96")
 CAB OPERATION: _____ (AUTD)
 GATE TYPE: _____ (FOLD CLR, FOLD BRZ, BLK SCZR)
LOCKS/CALL STATIONS/TRAVEL/DOORS (BY OTHERS)
 TRAVEL: _____
 ENTRANCE SIDE: _____
 DOOR SWING: _____
 LOCK TYPE: _____
 AUTO DOOR OP: _____
STANDARD OPTIONS PROVIDED
 BUTTON MARKING: _____ NUMERIC (1 to 4)
 HALL CALL KEYS: _____ ND
 HALL CALL FINISH: _____ MATCH CAR STATION
 HALL CALL SHAPE: _____ RECTANGULAR
 PREWIRE PACKAGE: _____ ND
 CONTROLLER LOCATION: _____ EXTERNAL

DRIVE ASSEMBLY MFR. _____ CONCORD
 MOTOR _____ 2.0 HP/1660 RPM w/Brake
 GEAR MODEL _____ 42:17:1 Ratio Gear Box
 MOTOR CONTROLLER _____ Preprogrammed VF Drive
SUSPENSION
 TYPE: _____ DUAL #60 ROLLER CHAIN
 CONSTRUCTION: _____ ANSI B291
 NOMINAL STRENGTH: _____ 9020 LBS PER CHAIN
ELECTRICAL
 POWER SUPPLY: _____ 60 Hz/1 Phase/230 volt

POT LIGHT FINISH (4): _____ (SS, BRZ, BRS)
 TRIM COLOUR: _____ (CLR, BRZ)
 CAR STATION PLATE (W/P/D): _____ (CLR, BRZ, BRS, SS)
 HAND RAIL TYPE: _____ (CLR, BRZ, BRS, SS)
 TELEPHONE BOX: _____ (CLR, BRZ, BRS, SS)
 GATES REQUIRED: _____ (AUTD, MAN)
 GATES: _____ (CLR, BRZ, BRS, SS)
 CAB SILL: _____ SS
 FOLD CLR, FOLD BRZ, BLK SCZR

LANDING 1	LANDING 2	LANDING 3	LANDING 4
			MIN OVERHEAD=96"/114"
			OH:
			HATCH SIDE

SMARTLOCK (BY OTHERS)
 EMI, PORTA

DISCONNECT (2): ND
 BUFFER SPRING: ND
 TEMP. RUN BUTTON: ND
 EXTRA CABLE (REMOVED): 0'
 WALL FASTENERS: _____ LAG

PROVISIONS BY OTHERS

***HOISTWAY, CONSTRUCTION SITE, CLEARANCE**

- HOISTWAY CONSTRUCTION AND PIT BY OTHERS. DUE TO LIMITED SPACE WITHIN THE HOISTWAY IT IS ESSENTIAL THAT THE PIT IS LEVEL AND WALLS ARE SQUARE AND PLUMB THROUGHOUT THE HOISTWAY. THE HOISTWAY FRAMING MUST BE WITHIN 13 mm (1/2") OF PLUMB AND SQUARE FROM TOP TO BOTTOM FOR PROPER OPERATION OF THE ELEVATOR THROUGHOUT THE HOISTWAY.
- CLEARANCES FROM DOOR SILL TO HOISTWAY DOOR TO BE 76 mm (3") MAXIMUM AND WITH CSA B44 (ASME/ANSI A17.1) CONSULT YOUR LOCAL INSPECTION AUTHORITIES FOR CODES WHICH MAY TAKE PRECEDENCE.
- HOISTWAY MUST HAVE A MINIMUM 192 mm x 192 mm (6" x 6") LOCKABLE ACCESS HATCH PROVIDED BY SAVARIA CONCORD LOCATED AT THE TOP OF THE HOISTWAY. LOCATION MUST BE IN AN AREA WHICH WILL PROVIDE ACCESS TO THE ELEVATOR DRIVE ASSEMBLY BY THE MANUAL LOWERING HANDLE. MANUAL LOWERING HANDLE WILL ENABLE USER TO OVERPOWER BRAKE AND LOWER CAR WITHOUT BODILY ENTRY TO THE SHAFTWAY.
- THE PIT FLOOR SHALL BE CONSTRUCTED TO WITHSTAND AN IMPACT LOAD OF 2903 KG (6400 LBS) REF. CSA B44 SECTION 2.11 (ASME/ANSI A17.1 SECTION 106.5)
- HOISTWAY TO BE FREE OF ALL PIPES, WIRING AND OBSTRUCTIONS NOT RELATED TO THE OPERATION OF THE ELEVATOR.
- HOISTWAY CONSTRUCTION REQUIREMENTS MAY VARY FROM REGION TO REGION. DIMENSIONS GIVEN ARE MANUFACTURERS RECOMMENDED CLEARANCES. THEY REFLECT RUNNING AND ACCESS CLEARANCES. CONSULT YOUR LOCAL AUTHORITY TO ASSURE COMPLIANCE WITH PROVINCE AND LOCAL CODES.

DIMENSIONS WARNING
 CONTRACTOR/CUSTOMER TO VERIFY ALL DIMENSIONS AND REPORT ANY DISCREPANCIES TO OUR OFFICE IMMEDIATELY.

***STRUCTURAL**

- A LOAD BEARING WALL IS REQUIRED TO SUSTAIN RAIL REACTIONS AS SPECIFIED IN KEY TO RAIL REACTIONS ON DRAWING. BUILDING CONTRACTOR TO CONTACT STRUCTURAL ENGINEER TO DETERMINE IF SUPPORTING WALL WILL SUSTAIN RAIL REACTIONS. FOR COMPLYING WITH LOCAL CODES.
- SUITABLE LINTELS MUST BE PROVIDED BY OWNER/AGENT.
- DOOR FRAMES ARE NOT DESIGNED TO SUPPORT OVERHEAD WALL LOADS.
- ALL FULL HEIGHT DOORS MUST BE ALIGNED WITH THE DOOR CENTERLINE SHOWN ON PLAN DETAIL. RECOMMEND INSTALLING A SOLID CORE 2032 mm (6'-8") HIGH DOOR WITH A MINIMUM CLEAR OPENING OF 813 mm (2'-8") WIDE.
- DOOR HANDLE AND LATCH SET REQUIRED FOR ALL FULL SIZE DOORS.
- SEE INSTALLATION MANUAL FOR DETAILS ON THE INTERLOCKS. INTERLOCKS ARE REQUIRED FOR ALL FULL SIZE DOORS.

***ELECTRICAL**

- THE ELEVATOR CONTROLLER IS 620 mm (24.4") WIDE X 584 mm (23") HIGH X 170 mm (6.7") DEEP. THE CONTROLLER IS PROVIDED BY SAVARIA CONCORD AND IS EITHER A. ATTACHED TO THE RAIL WALL INSIDE THE HOISTWAY BETWEEN THE 1ST RAILS WITH ACCESS EITHER UNDER THE CAB OR THROUGH THE CAB OF THE ELEVATOR; OR B. IN A REMOTE LOCATION EXTERNAL TO HOISTWAY, THAT NEEDS PROPER STRUCTURAL WALL TO SUPPORT THE CONTROLLER ON ALL 4 CORNERS HOLES POSITION ARE = 597 mm (23.5") WIDE BY 546 mm (21.5") HIGH.
- ARRANGE FOR A POWER SUPPLY WITHIN SIGHT OR NEXT TO THE ELEVATOR CONTROLLER PRIOR TO DELIVERY OF THE UNIT(BOTH 115 VOLT & 208/240 VOLT). THE 208/240 VOLT CIRCUIT SHALL ORIGINATE FROM A LOCKABLE 2 POLE FUSED DISCONNECT (20 AMP RK 5 RATED FUSED LOCATED NEAR THE RESIDENCES. INCOMING ELECTRICAL PANEL THE ELECTRICAL CIRCUIT PROVIDED FOR THE CONTROLLER SHALL BE 208/240 VOLT, SINGLE PHASE, DE-DIATED CIRCUIT WITH NEUTRAL AND GROUND. FUSING MUST BE SELECTIVE. GROUNDING FUSE 208/240 VOLT FOR 20 AMP SERVICE. FUSE 115 VOLT FOR 15 AMP SERVICE FOR CAR LIGHT. A LOCKABLE AUXILIARY 240 VOLT AND 115 VOLT DISCONNECT IS REQUIRED INSIDE THE HOISTWAY OR IN SIGHT OF THE CONTROLLER. ALL ELECTRICAL TO DISCONNECTS SHALL BE PROVIDED BY OTHERS (CUSTOMER).
- WALL ELECTRICAL BOXES.
- INTERLOCKABLE WIRING AND CONNECTIONS TO HALL-CALLS, PIT SWITCH AND INTERLOCK FUSE PROVIDED.
- THE TERMININATION SHALL BE NOT LESS THAN 200 LX (9 FCD) AT THE FLOOR LEVEL IN ALL MACHINE ROOMS AND MACHINERY SPACES. THE SWITCH MUST BE GUARDED TO WITHIN 457 mm (18") OF THE HOISTWAY ACCESS. THE LIGHT MUST BE GUARDED TO PREVENT ACCIDENTAL BREAKAGE OR CONTACT WITH THE HOT BULB. THE SWITCH, LIGHT, AND GUARD ARE PROVIDED AND INSTALLED BY OTHERS. (MUST COMPLY WITH APPLICABLE CODES).
- IF A TELEPHONE CIRCUIT IS REQUIRED OPTION FOR ELEVATOR JACK IS PROVIDED AND INSTALLED BY OTHERS. THIS CIRCUIT SHALL BE BROUGHT TO A LOCATION NEXT TO THE CONTROLLER AND BE AVAILABLE TO CONNECT AND TEST UPON ELEVATOR INSTALLATION.
- WHEN CONTROLLER EXTERNAL
- LOCATION ACCESS- CONTROLLER ROOM LOCATED AT THE LOWEST LEVEL. ACCESS TO HOISTWAY MUST BE PROVIDED BY OTHERS. DRAWINGS FIELD ADJUSTMENT BY INSTALLER MAY BE NECESSARY TO MEET ON SITE CONDITIONS OR REGULATIONS TO CONTROLLER ROOM TO BE THROUGH A SELF CLOSING LOCKABLE DOOR WHERE CODE CONSIDER IT AS A MACHINE ROOM
- WHEN APPLICABLE SLEEVES FOR ELECTRIC LINES-
- FROM CONTROLLER ROOM TO RUNWAY AS REQUIRED.
- POSITION PER INSTALLERS INSTRUCTIONS.

***CODE**

- ALTHOUGH THE ELEVATOR IS DESIGNED TO MEET CSA B44 (ANSI A17.1). LOCAL CODES MAY VARY. DEALER IS RESPONSIBLE FOR COMPLYING WITH LOCAL CODES.

NOTE A
 ALL COMPONENTS WEIGHTS CAN BE FOUND IN THE PLANNING GUIDE

NOTE B
 ALL INFORMATION IS SUBJECT TO CHANGE.
 PLEASE REFERENCE OUR ON-LINE DRAWINGS AT
 www.savariacncord.com FOR THE MOST RECENT UPDATES

RESIDENTIAL ELEVATOR

ECLIPSE MODEL 36X48 TYPE 5

CUSTOMER:	DATE:
PROJECT:	REVISION DATE:
LOCATION:	COMPLETED BY:

THE INFORMATION DISCLOSED HEREIN IS THE EXCLUSIVE PROPERTY OF **savaria**

AND MAY NOT BE USED BY OTHERS WITHOUT PRIOR WRITTEN CONSENT

SHEET # 1/1