



Orion[®]
LU/LA
Commercial
Elevator

Planning
Guide

 savaria.

Applicable Codes:

ASME A17.1, Section 5.2
CAN/CSA B44, Section 5.2

Important Notice

This Planning Guide provides nominal dimensions and specifications useful for the initial planning of a project. Before beginning actual construction, make sure you have the installation (shop) drawings customized with specifications and dimensions for your specific project.

Lift configurations and dimensions are in accordance with our interpretation of the standards set forth by the codes listed below. Please consult Savaria or the authorized Savaria dealer in your area for more specific information pertaining to your project, including any discrepancy between referenced standards and those of any local codes or laws.

The dimensions and specifications in this Planning Guide are subject to change (without notice) due to product enhancements and continually evolving codes and product applications.

Visit our website www.savaria.com for the most current drawings and dimensions.

Purpose of This Guide

This guide assists architects, contractors, and lift professionals to incorporate the Orion Elevator into a residential design. The design and manufacture of the Orion Elevator meets the requirements of the following codes and standards:

- ASME A17.1/CSA B44 2000, Section 5.2
- ASME A17.1/CSA B44 2004, Section 5.2
- ASME A17.1 2004, Addendum 2005, Section 5.2
- ASME A17.1/CSA B44 2007, Section 5.2
- ASME A17.1/CSA B44 2004, Addendum 2008, Section 5.2
- ASME A17.1/CSA B44 2010, Section 5.2
- ASME A17.1/CSA B44 2013, Section 5.2
- ASME A17.1/CSA B44 2016, Section 5.2
- ASME A17.1/CSA B44 2019, Section 5.

This unique elevator is designed to help solve accessibility problems in commercial buildings, and meets state and national codes covering the Limited Use/Limited Application (LULA) elevators.

We strongly recommend you contact the Authority Having Jurisdiction (AHJ) in the region where the equipment will be installed. Become familiar with all requirements governing the installation and use of elevators in public and private buildings. It is extremely important for you to know and adhere to all regulations concerning installation and use of elevators.

Revision History of This Guide

September 1, 2006 - Initial release

May 22, 2008 - March 11, 2024 - Miscellaneous Revisions

January 27, 2025 - Revised page 8, 10 and 13

November 28, 2025 - Revised document format and code update

March 17, 2026 - Revised page 8

Summary: This document highlights two major changes on commercial elevators with respect to the ASME A17.1 2019 code year. This change brings an increase in cost, an added complexity to project management/installation, and new requirements for ongoing 24/7 remote monitoring.

Reason for the change: Provide hearing-impaired riders with an improved method of communication with emergency services and monitor the elevator entrance space to assist approaching traffic.

Solution: The elevator will now be equipped with an audio/visual, two-way communication and 3D cab entrance monitoring device on each entrance. Remote monitoring services must be able to see the entire cab and communicate via LCD screen.

Elevator Equipment

When quoting and ordering the equipment from Savaria it is imperative that you select the correct code year. If the 2019 code is not selected, these additional items—that have a substantial cost—will not be budgeted.

Savaria provides the main components. However, there are several items that need to be supplied by others to accommodate the system.

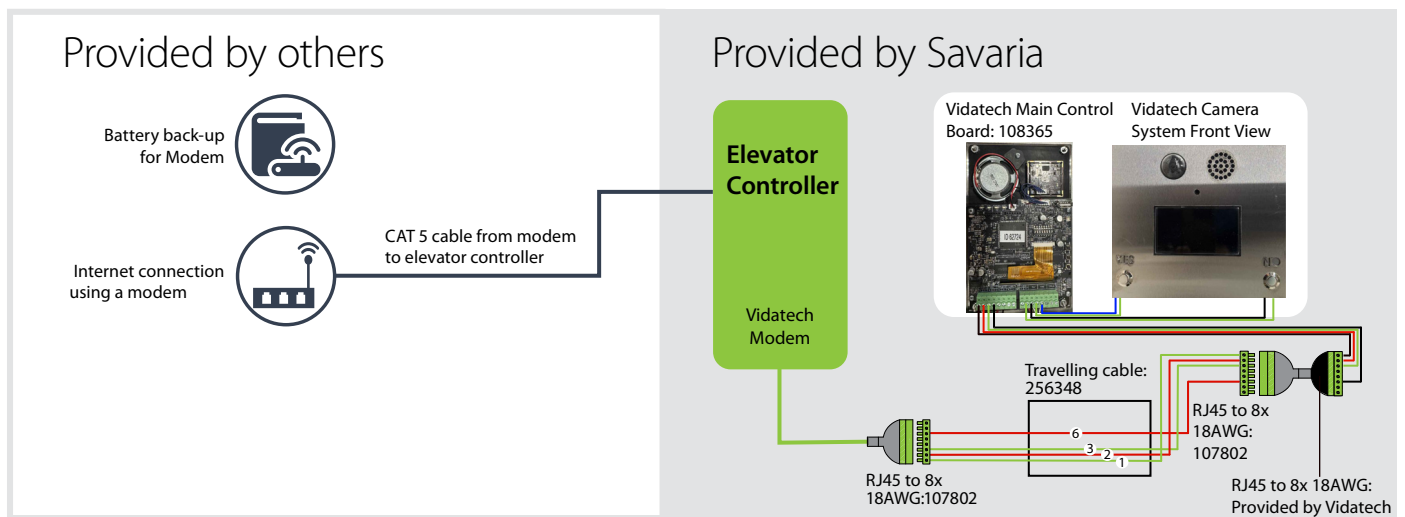

Component	Provided by Savaria
Vidatech System: Adjustable camera, Vidatech main control board, LCD display	YES
3D cab entrance monitoring device	YES
Battery backup for modem	NO
Vidatech Modem	YES
Modem CAT5 cable	NO
Internet	NO

Key Points

- The supplied connection must use Internet (Modem).
- Vidatech provides VOIP (Voice over Internet Protocol) for the required phone.
- At the time of installation, the elevator contractor must set up a pre-recorded message to identify the location and note the elevator camera's Elevator ID number. This ID number is located on the back of the camera and will be provided to the owner and monitoring company.

24/7 Remote Monitoring

The monitoring company you currently recommend and/or use may not be set up to handle the new system, or even know what's involved. It's important that you understand what's needed under the new code and ensure you work with someone who has the capabilities to support this system.

Here's how it works

1. When an emergency call is received by the monitoring company, they will need to understand if the elevator in question is installed in accordance with 2019 code and has emergency audio/visual capabilities.
2. The elevator will have VOIP system. The monitoring company can either identify the unit from the incoming phone number and cross reference the camera elevator ID number on file, or the pre-recorded message will notify the monitoring company of which specific elevator and location is dialing in.
The elevator contractor must set up the pre-recorded message at time of install. The message can include the business name, building address. If there are multiple elevators in the same location, the pre-recorded messages must be set up to uniquely identify each unit.
3. If there is no audio communication on the received emergency call, the monitoring company will need to view the inside of the elevator cab by going online to Vidatechstorm.com and inputting the specific Elevator ID number.
4. Once connected through Vidatech, the monitoring company will be able to see inside the elevator and communicate with any riders using text on the LCD screen and yes and no buttons on the COP.

Other Useful Links

Link to Vidatech website Elevator ID Page:
<https://www.vidatechstorm.com/>

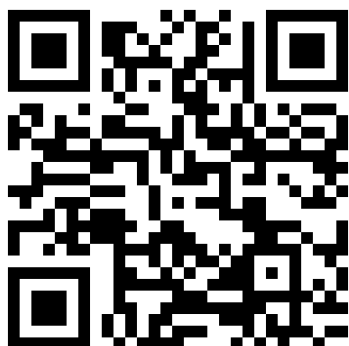

3D Cab Entrance Monitoring Device

The monitoring device is mounted inside the cab above the entrance.



Table of Contents

- Product Elements Diagram 6
- Technical Specification 8
- Provisions By Others 10
 - General 10
 - Structural 10
 - Electrical 10
- Site Preparation 11
 - Entrances 11
 - Hoistway 11
- Drawings 12
- Specification for Part 5.3 Compliance 36
 - Part 1 General 36
 - Part 2 Product 38
 - Part 3 Execution 39
 - End of Section 39

Product Elements Diagram

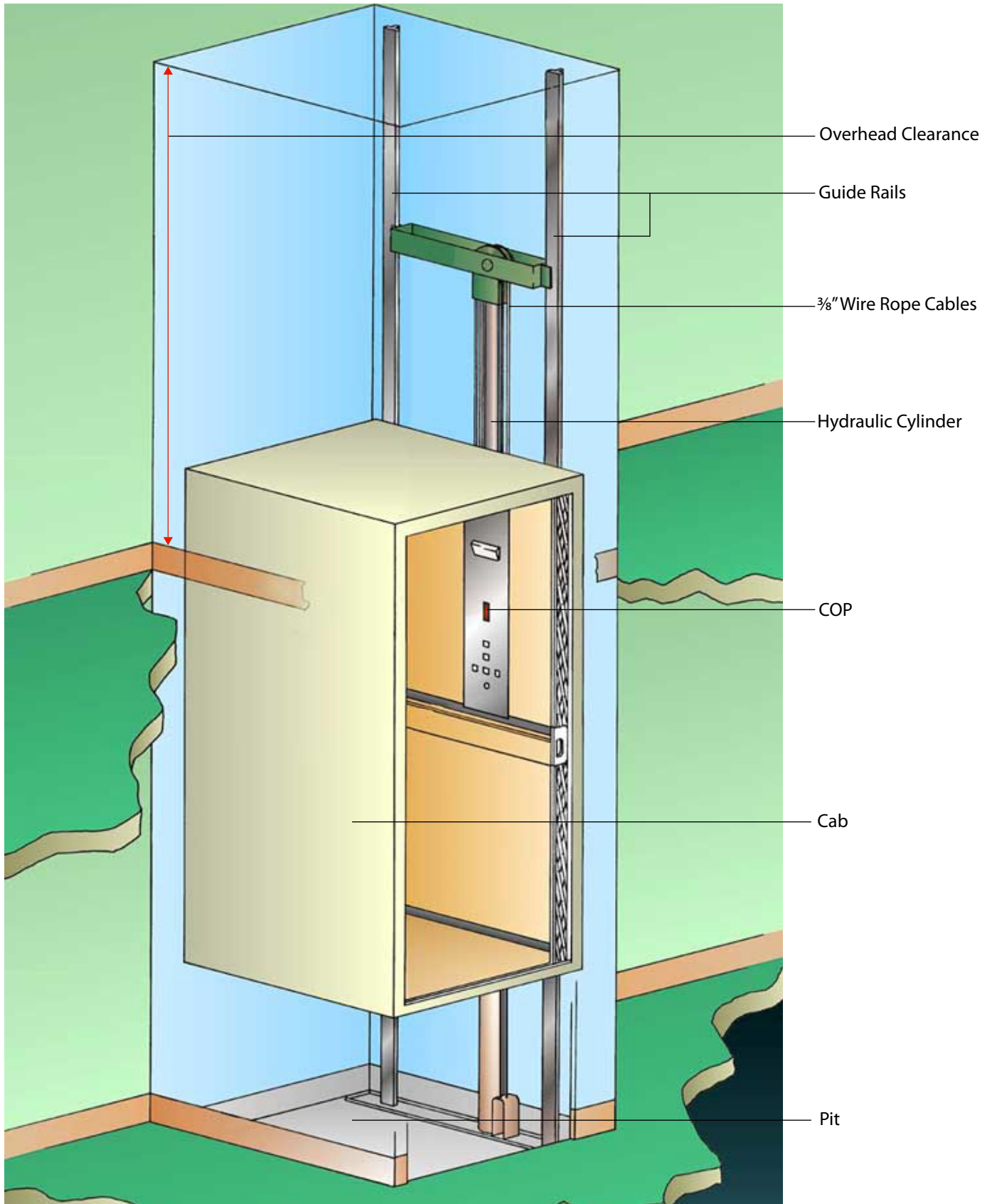

Figure 1: Orion in Hoistway

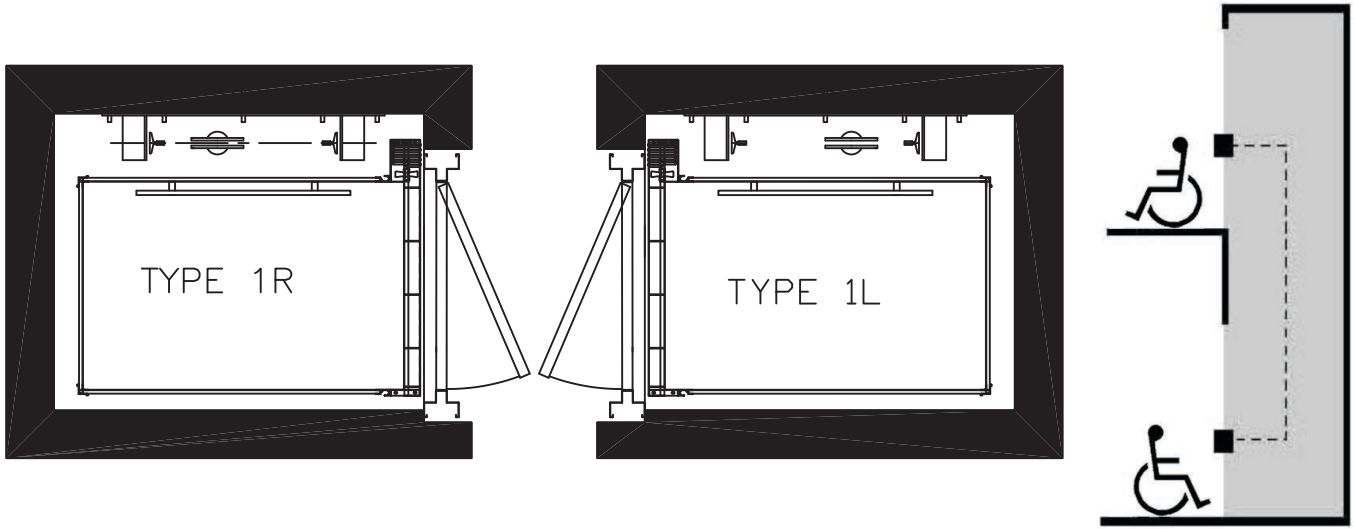

Figure 2: Types 1 Cab

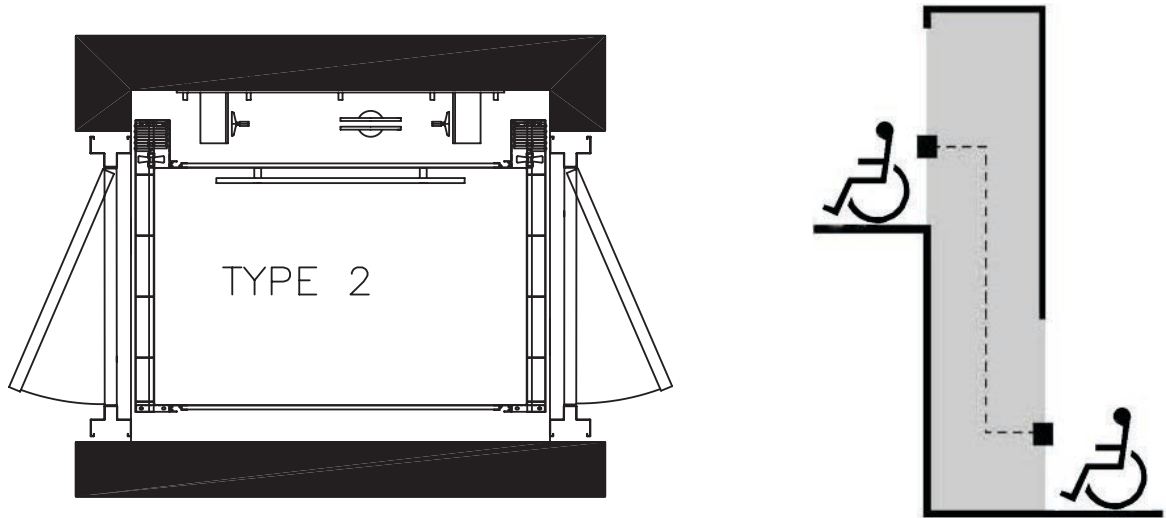

Figure 3: Type 2 Cab

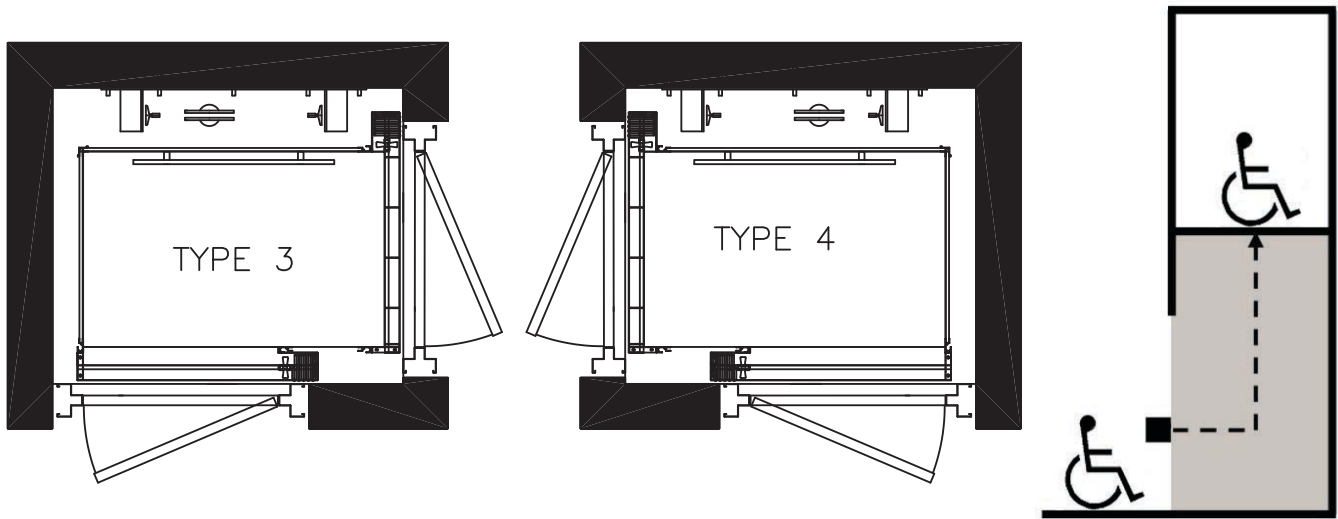

Figure 4: Type 3 and 4 Cab

Technical Specifications

Specification	Specification Data
Load capacity	635 kg (1400 lbs)
Nominal speed	0.15 m/s (30 ft/min)
Power supply	208 Volt, three-phase, 30 Amps, 60 Hz 240 Volt, single-phase, 40 Amps, 60 Hz
Lighting supply	120 Volt, 15 Amps, 60 Hz
Drive system	<ul style="list-style-type: none"> • 1:2 cable hydraulic with slack cable safety device • 5 hp submersed motor • Two 3/8" diameter steel aircraft cables; rope wedge sockets
Operating temperature	+10 C to +35 C 20 to 80% humidity (non-condensing)
Cab sizes	Type 1,2,3 and 4 <ul style="list-style-type: none"> • W48" x 54" x H84" (1219 mm x 1371 mm x 2134 mm) • W42" x L60" x H84" (1067 mm x 1524 mm x 2134 mm) • W51" x L51" x H84" (1295 mm x 1295 mm x 2134 mm)
Floor by Others (in cab)	5/8" (15.9 mm) maximum
Cab panel finish	Steel panel cab with optional laminates
Maximum travel	18 inches (457 mm) to 25 feet (7.6 m) ANSI, up to 40 feet residential and CSA
Noise level (Typical installation)	73.2 dBA; measured at a height of 1m, distance of 1m, in front of tank, in closed machine room
Control System	Automatic user interface; Programmable Logic Controller (PLC)
Controller Specs	2G, Shock: 11G, Weight: Approx. 90 lbs
Distance Between 2 landings	18" (457 mm) minimum
Daily cycle	Normal: 30, Heavy: 75, Excessive: 100 Maximum starts in 1 hour on standard installation: 15 NOTE: Consult your Sales Representative if there's a chance you may exceed these amounts.
Levels serviced	Up to 6 stops (maximum 6 landing doors on all cab types)
Pit Depth Required	14 inches (355 mm) minimum up to 96 inches (2438 mm)
Minimum Overhead Clearance	108" (2743 mm) for existing construction without overspeed governor 120" (3048 mm) for existing construction with overspeed governor 134" (3404 mm) for new construction 110" (2794 mm) for Orion17 cab
Hall Station and Control Panel Finish	Rectangular stainless steel (standard) or brass (optional)
machine room temperature	80 degrees F (27 degrees C); tank generating ~ 3200 BTU/HR to 6400 BTU/HR

Specification	Specification Data
Standard Features	<ul style="list-style-type: none"> • 8 lb/ ft T-rail system • Anti-creep device • Architectural white ceiling • Automatic cab ON/OFF lighting • Car top stop switch and car top prop (where required) • Data plates, capacity tags and rope tags • Digital floor and directional indicator • Emergency manual lowering, stop key switch and alarm buttons • Emergency battery back-up for lighting, alarm and emergency lowering • Floor specific battery lowering • Illuminated cab operating buttons • Limited warranty covers the repair or replacement of any defective parts for a period of 36 months from date of shipment • Magnetic floor selection, stopping and re-leveling • Manual reset slack rope safety switch • Maintenance pit props • Pit switch • Pit clearance switch • Presentation drawings • Pump run timer • Rail sections (8 ft standard or 16 ft optional) • LED lights in stainless steel • Recessed plywood floor • Two 12V, 4AH, sealed no maintenance batteries with 24 V, 4 Amp Smart Charge™ battery charge • Variable speed pressure compensated valve with manual lowering • Upper and lower terminal limits
Options	<ul style="list-style-type: none"> • 2 speed sliding doors for drywall or Masonry hoistway finish • 2 speed steel doors with infrared closing sensors in black, architectural white or stainless steel • Steel panels with plastic laminate in a variety of colors • 15 ft, 20 ft, or 25 ft hose with flow control • 90 degree entry/exit cab • Automatic cab gate operator and automatic hoistway door operator • Automatic home landing to pre-selected floor • Brass COP, hall call stations, handrail and recessed down lights • Buffer springs, 15" (381 mm) minimum pit depth required • Conductor cable for hoistway to pump wiring, 40 ft (12.19 m), 60 ft (18.29 m) or 80 ft (24.38 m) • Firefighter service - phase 1 and 2 (dependable on applicable code year) • Flow control, overspeed valve and pipe rupture valve • Hands-free telephone • Overspeed governor • Fire recall service • Raised plastic laminated panels in a choice of 7 colors • Recessed stainless steel or brass telephone cabinet • Savaria Link remote monitoring

Provisions By Others

GENERAL

Construction Site

Owner/agent to provide all masonry, carpentry and drywall work as required and shall patch and make good (including finish painting) all areas where walls/floors may need to be cut, drilled or altered in any way to permit the proper installation of the lift.

Dimensions

Contractor/customer to verify all dimensions and report any discrepancies to our office immediately.

Savaria Link

If you have the Savaria Link Ethernet remote monitoring option, ensure that you have an Ethernet connection with Internet capability in the vicinity of the unit's controller.

If you have the Savaria Link Wireless remote monitoring option, ensure that you have a wireless signal with Internet capability in the vicinity of the unit's controller.

STRUCTURAL

Floor Loads

Structural engineer to assure that the building and shaft will safely support all loads imposed by the lift equipment. Refer to the tables on the installation drawings for loads imposed by the equipment.

Wall Loads

Suitable lintels must be provided by the owner/agent. Door frames are not designed to support overhead wall loads

ELECTRICAL

Electrical Requirements

Power supply with a lockable fused disconnect and auxiliary contact to break the battery feed, or circuit breakers with a 3-pole breaker for battery feed required in compliance with electrical code (contact your Savaria dealer or refer to the table below for OEM part numbers).

Permanent Power

Permanent power of 240V single-phase 40 Amp or 208V three-phase 30 Amp must be supplied by others before installation

Disconnect Switch Types & Accessories	Cutler Hammer	Federal Pioneer	Siemens
1 Phase 5 H.P. Pump Unit			
2 Pole Solid Neutral 240V 1 PH	1HD222N	1622SN	ID322
Required Auxiliary Contact	DS16CP	E1K-1AEV-W94	MISSAK 116
Required Type "D" Fuse (Buss type "FRN" or equal)	2@40 amps	2@40 amps	2@40 amps
3 Phase 5 H.P. Pump Unit			
2 Pole Solid Neutral 240V 1 PH	1HD321N	1332SN	ID321
Required Auxiliary Contact	DS16CP	E1K-1AEV-W94	MISSAK 116
Required Type "D" Fuse (Buss type "FRN" or equal)	3@30 amps	3@30 amps	3@30 amps
Cab Lighting			
1 Pole Solid Neutral 120V 1 PH	GP 111N	86211	CFN 211
Required Type "D" Fuse (Buss type "T" or equal)	1@15 amps	1@15 amps	1@15 amps

Site Preparation

The following items **MUST** be completed prior to installation of the elevator.

Entrances

Entrance assemblies must be adjusted to align with the platform and interlock equipment, securely fastened to walls by the elevator contractor. Others to allow an adequate rough opening.

Hoistway

The hoistway must be designed and built in accordance with the "Safety Code for Elevators and Escalators" (ASME A17.1) and all state and local codes.

Due to close running clearances, the owner/agent must ensure that the hoistway and pit (where provided) are level, plumb and square and are in accordance with the dimensions on these drawings

Drawings

Machine Room

- Machine room must be built in accordance with elevator manufacturer and applicable building codes and regulations. Adequate ventilation is required to maintain a temperature of 18°C to 25°C (64.4°F to 77°F) for output of 3600 BTU per hour.
- A convenience outlet of 120 VAC 15 Amp single-phase with G.F.I. shall be located next to the light switch in the machine room (provided and installed by others).
- Provide lockable, in open position, fused disconnect switches located adjacent to the elevator controller. Fusing must be selectively coordinated. Fuse either 208V three-phase w/30 Amp or 240V single-phase w/40 Amp service; fuse 120V for 15 Amp service for cab lighting. (Must comply with applicable codes.)
- Provided and installed by others, the electrical circuit with equipment ground, will provide either 30 Amp 208V three-phase or 40 Amp 240V single-phase, terminating on the line side terminal lugs of the disconnect.
- Disconnect switch to have auxiliary normally open interlock switch. Interlock equal to Square D EK-300-Z.
- 30" wide x 36" deep work space required in front of the disconnects and the elevator controller.
- Machine room lighting shall be a minimum of 19 foot-candles (204 lux) at working surfaces, guarded to prevent accidental breakage or contact with the hot bulb. The light switch must be within 18" of the strike side of the machine room door. The switch, light, wiring, and guard are provided and installed by others.
- A telephone line circuit shall be provided and installed by others. The circuit must be routed in conduit to the machine room controller and connected to either a dedicated outside line or a 24-hour central exchange.
- Elevator controller/pump unit dimensions - 27.5" wide x 62.8" high x 16.15" deep with 39" clear space in front.
- Machine room access door must be self closing, self locking, key locked and have a spring return latch.
- Consult local building codes for door construction. The door and hardware are both provided and installed by others.
- Machine room is required to be free of all pipes, wiring and obstructions not related to the operation of the elevator. Provide a 4 inch conduit from the lift shaft to the remote machine room.

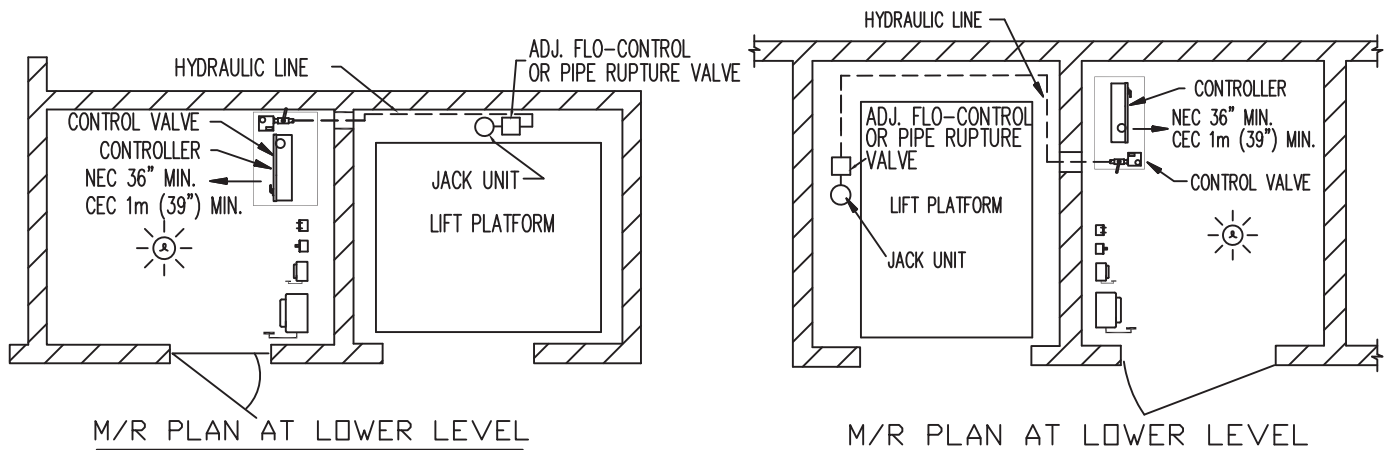

Figure 5: Left and Right Hand Position

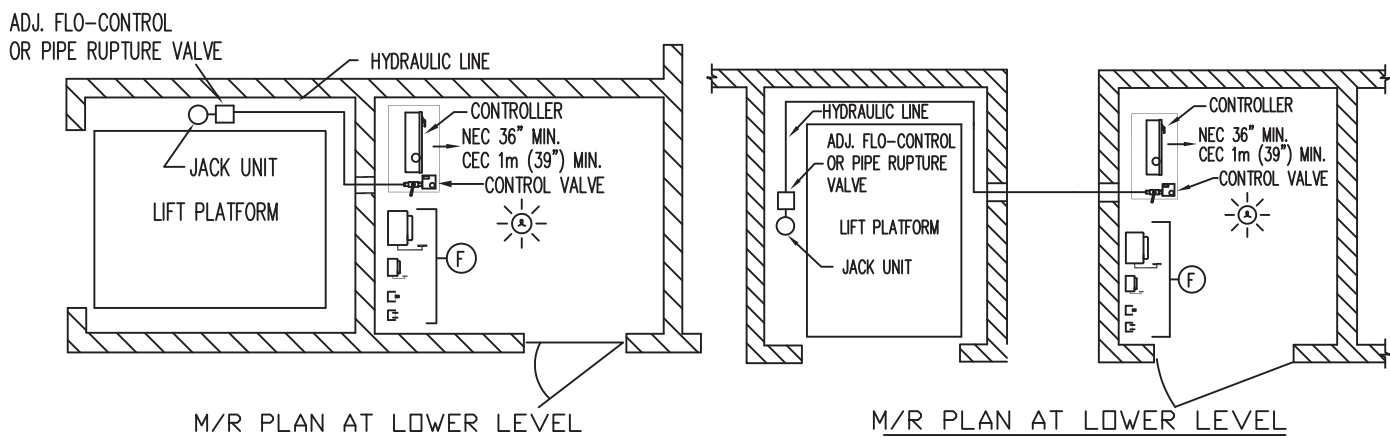

Figure 6: Back and Remote Positions

Machine Room Dimensions



NOTICE

Confirm Requirements with local codes

Position of Doors and Components are subject to vary. Maintain minimum distance in front of components.

Raceway between the machine room and hoistway will need to be provided. Consult your installation company for size and location.

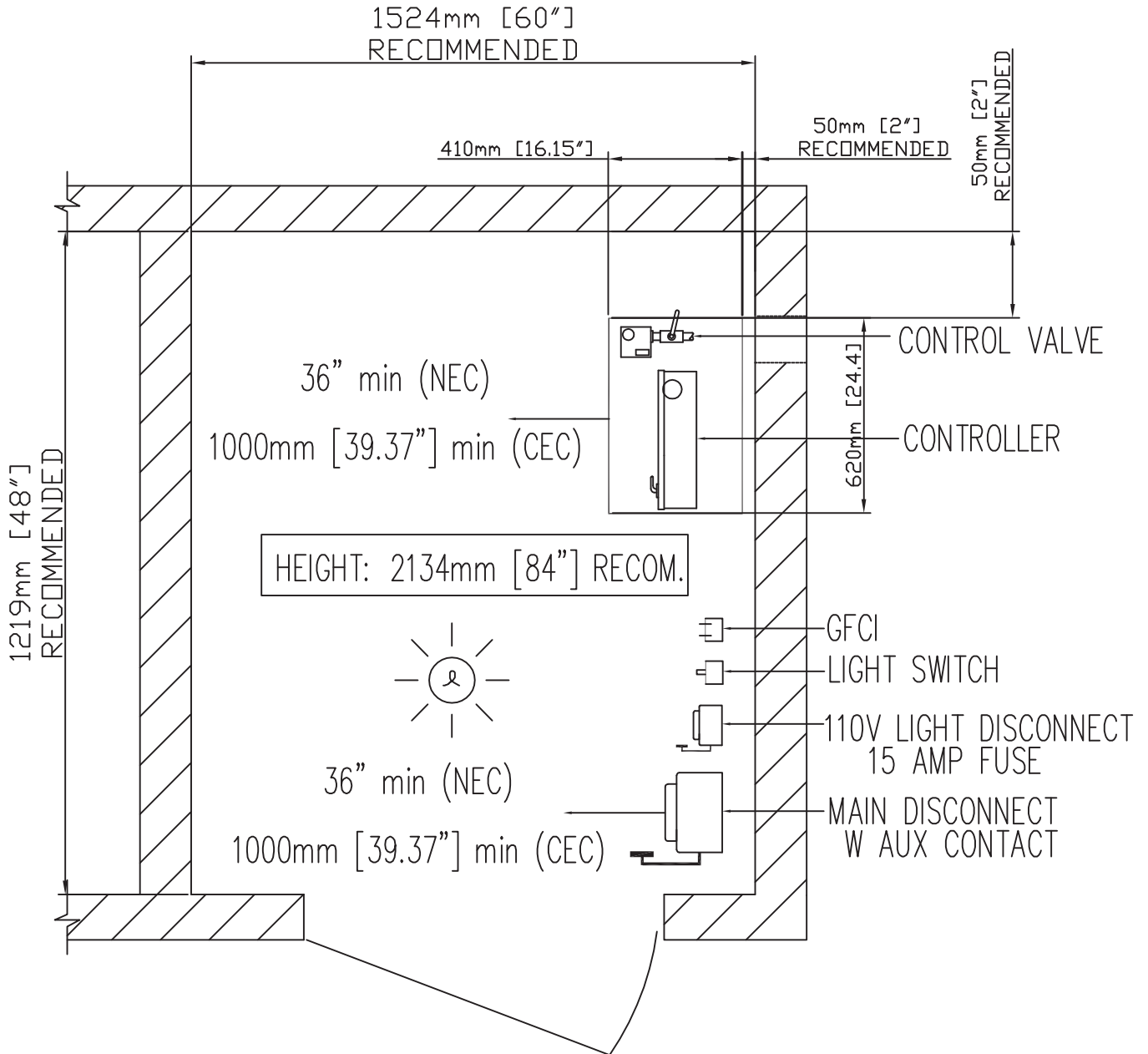

Figure 7: Machine Room Dimensions

Hoistway and Pit Electrical Notes

- A load bearing wall is required to sustain rail reactions. See page 18 for rail reactions.
- Suggested hoistway pit floor construction consists of an 8" (203 mm) concrete slab poured on a natural or compacted soil with a minimum allowable bearing pressure of 1.0 KSF.
- The minimum compressive strength of the concrete at 28 days must be no less than 3000 PSI. #5 reinforcing steel (grade 60) must be placed at the bottom of the slab in 2 traverse directions and at a spacing of 12" (305 mm).
- Hoistway pit floor to support a load of 10 kips (10,000 lbs)/44.48KN (includes impact).
- 108" (2743 mm) minimum overhead clearance required above the top landing floor (for existing construction without overspeed governor).
- 120" (3048 mm) minimum overhead clearance required above the top landing floor (for existing construction with overspeed governor).
- 134" (3404 mm) minimum overhead clearance required above the top landing floor (for new construction).
- 14" (356 mm) minimum pit. A clearance device is provided to attain required 36" (914 mm) refuge space.
- The Dedicated GFI outlet is approximately 24" up from the lower landing finished floor light switch mounted directly above.
- 9" Clear Distance from the inside finished surface of hoistway to edge of the electrical box.
- Hoistway sizes reflect running and access clearances only. Consult your local AHJ to assure compliance with local codes.
- Hoistway is required to be free of all pipes, wiring and obstructions not related to the operation of the elevator.
- If a dedicated pit light is required by your local AHJ, please follow the guidelines below for accommodating this in your hoistway

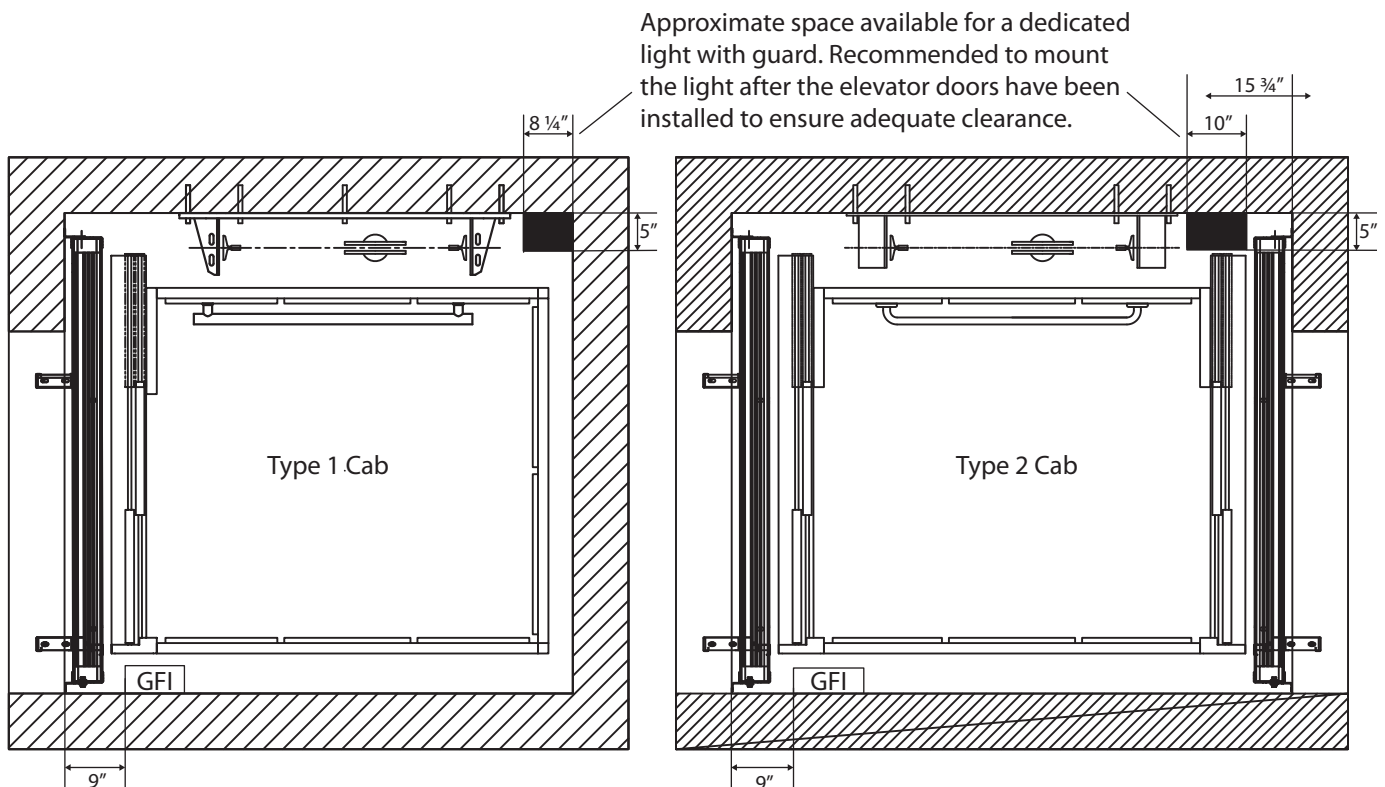

Figure 8: Hoistway measurements

Controller Tank

- Hydraulic hose connection ports on either side of the tank
- Built in handles on either side of the tank
- Isolation mounting of pump motor valve assembly minimizes operating noise

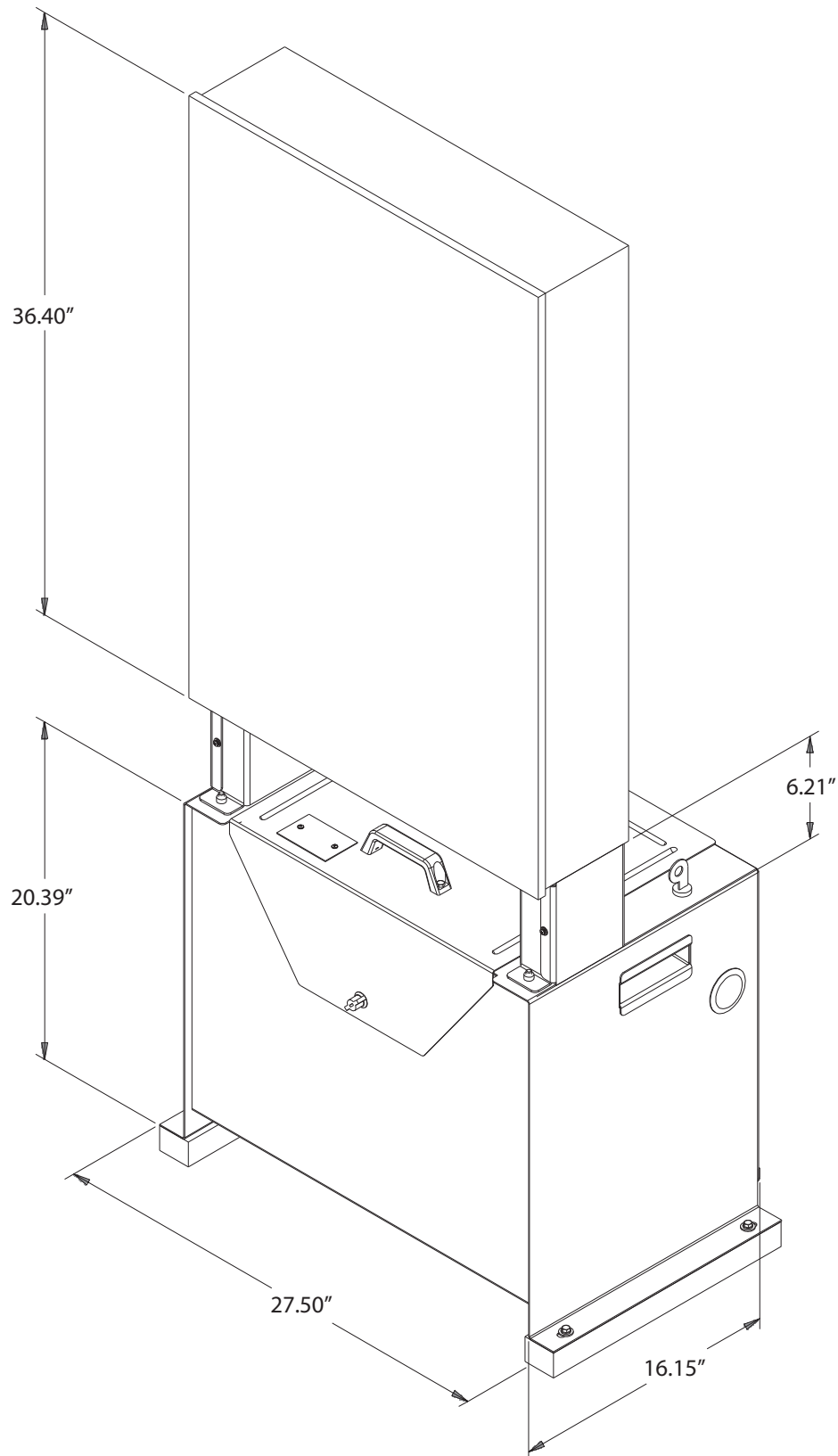

Figure 9: Controller Tank

Specification	Specification Data
Dimesions	H 57" x W 28" x D 17" (Approx.)
Minimum Required Clearance in Front	39"
Valve and Manual Lowering Handle Location	Inside tank
Rupture Valve Test	T-fitting factory installed
Tank to Controller Wiring	Quick connect valve and motor wiring
Controller Layout	PLC
Keyed Lock to Tank	Yes
Machine Room Required	Yes
Tank Capacity	57-63 L/15-16.5 Gal
Max. Dry Weight	55 kg (147 lbs)
Max. Filled Weight	117 kg (312 lbs)
Operating Environment	18°C to 25°C(64.4°F to 77°F)
Operating Volume	57 dBA

Orion 48" x 54" Type 1 with 2 Speed Door

NOTICE
 Plan view drawing can be reversed for Right Hand applications.
 For Masonry or Drywall Entrance Details, refer to the drawings on pages 30-33.
 The cab dimensions provided in this manual are based on a PLAM cab.

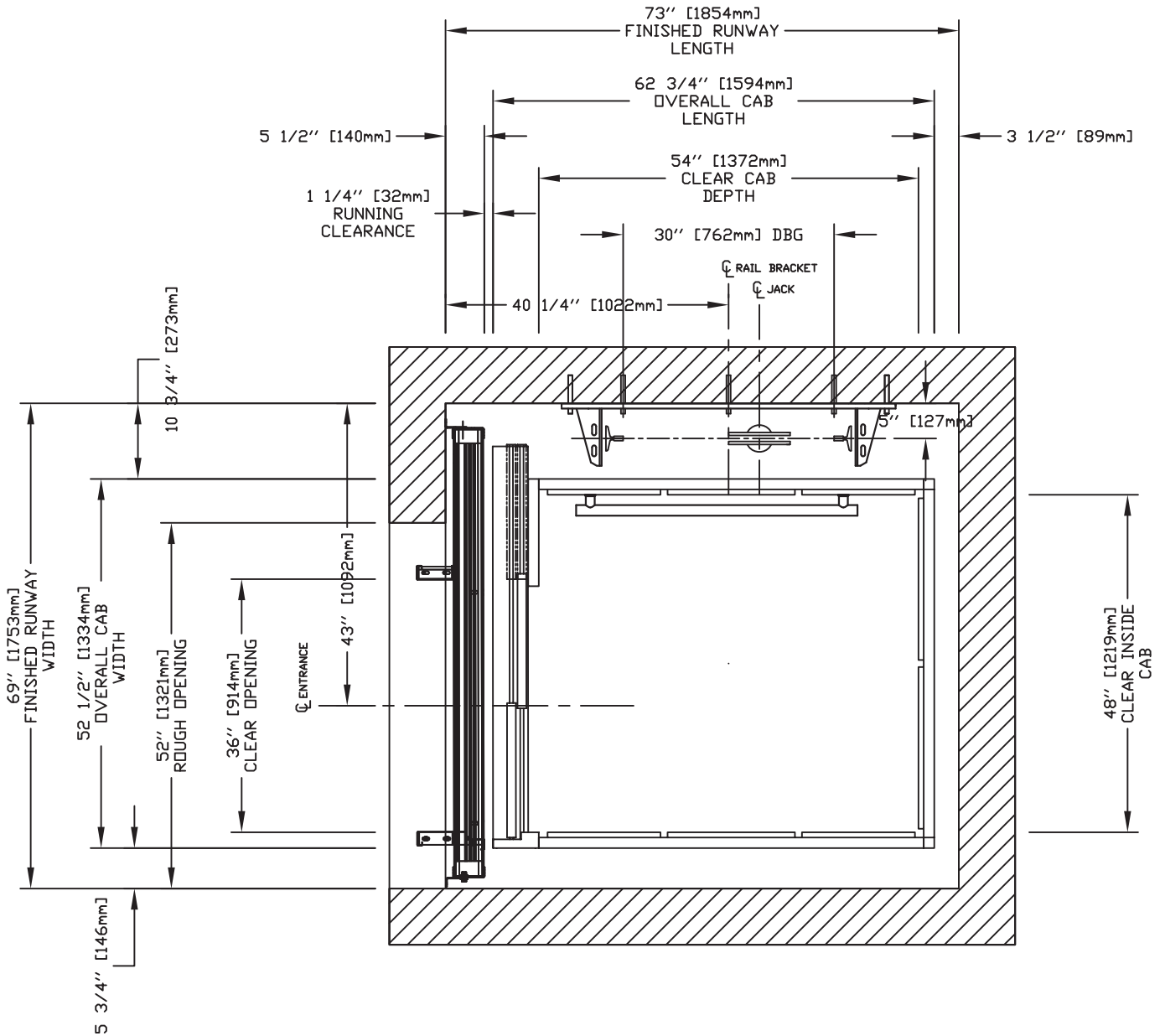

Figure 10: Type 1 48" x 54" with 2 Speed Doors

Orion 48" x 54" Type 1 with 2 Speed Door

NOTICE
 For Masonry or Drywall Entrance Details, refer to the drawings on pages 30-33.
 The cab dimensions provided in this manual are based on a PLAM cab.

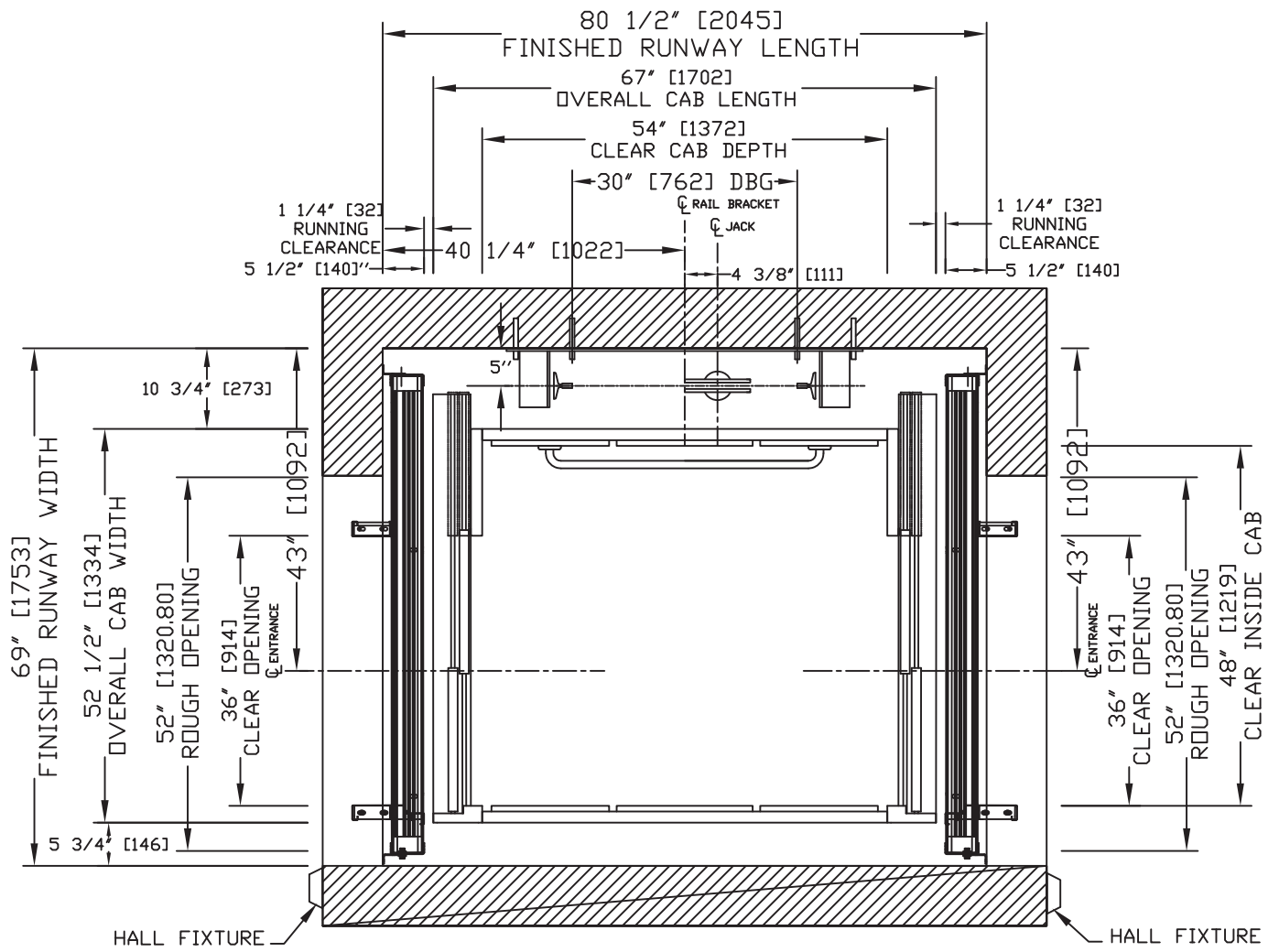



Figure 11: Type 2 - 48" x 54" with 2 Speed Doors

Orion 54" x 54" Type 3/4 with 2 Speed Door

NOTICE
 Plan view drawing can be reversed for Right Hand applications.
 For Masonry or Drywall Entrance Details, refer to the drawings on pages 30-33.
 The cab dimensions provided in this manual are based on a PLAM cab.

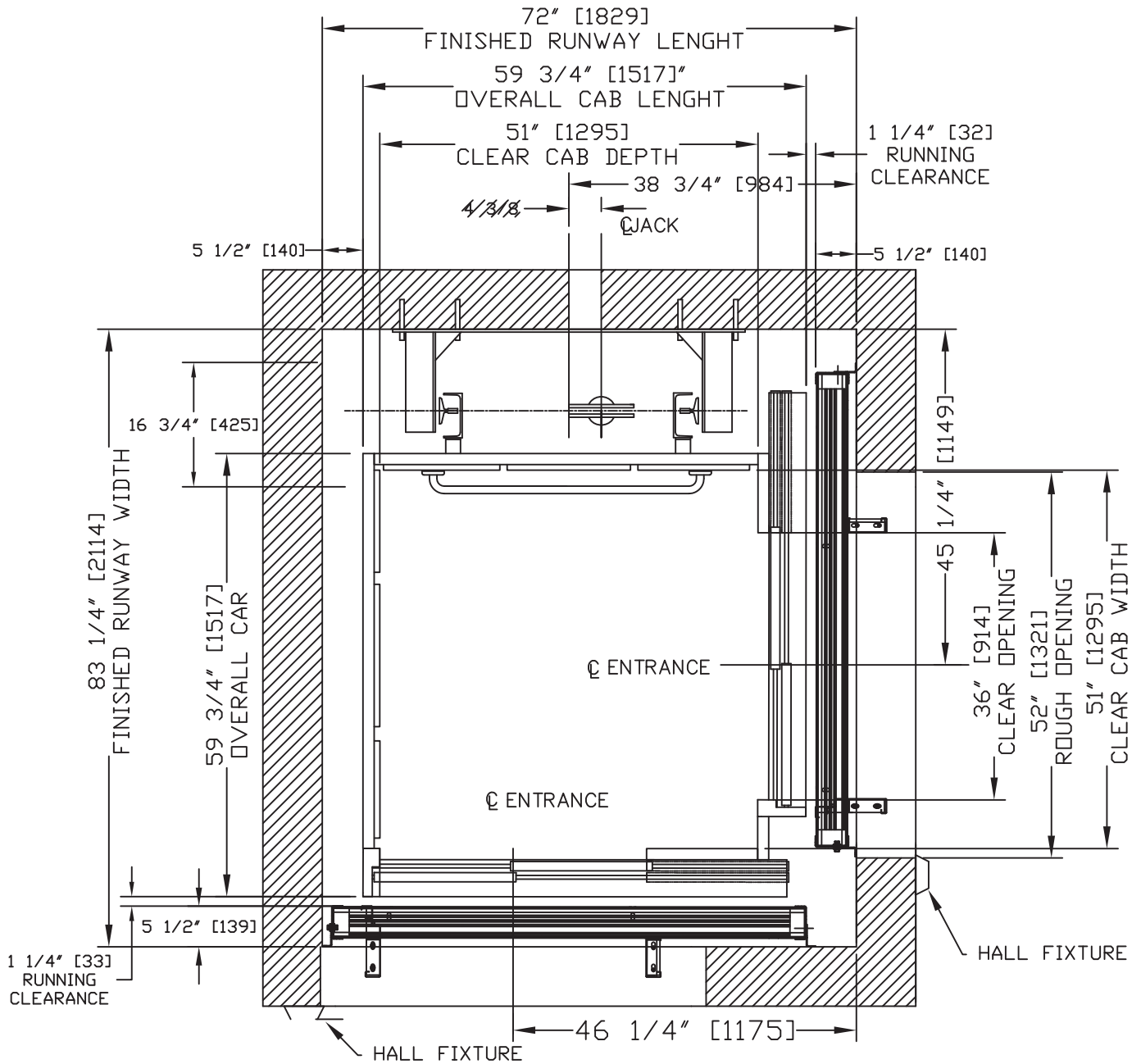



Figure 12: Type 3/4 - 51' x 51" with 2 Speed Doors

Orion 42" x 60" Type 1 with 2 Speed Door

NOTICE
 Plan view drawing can be reversed for Right Hand applications.
 For Masonry or Drywall Entrance Details, refer to the drawings on pages 30-33.
 The cab dimensions provided in this manual are based on a PLAM cab.

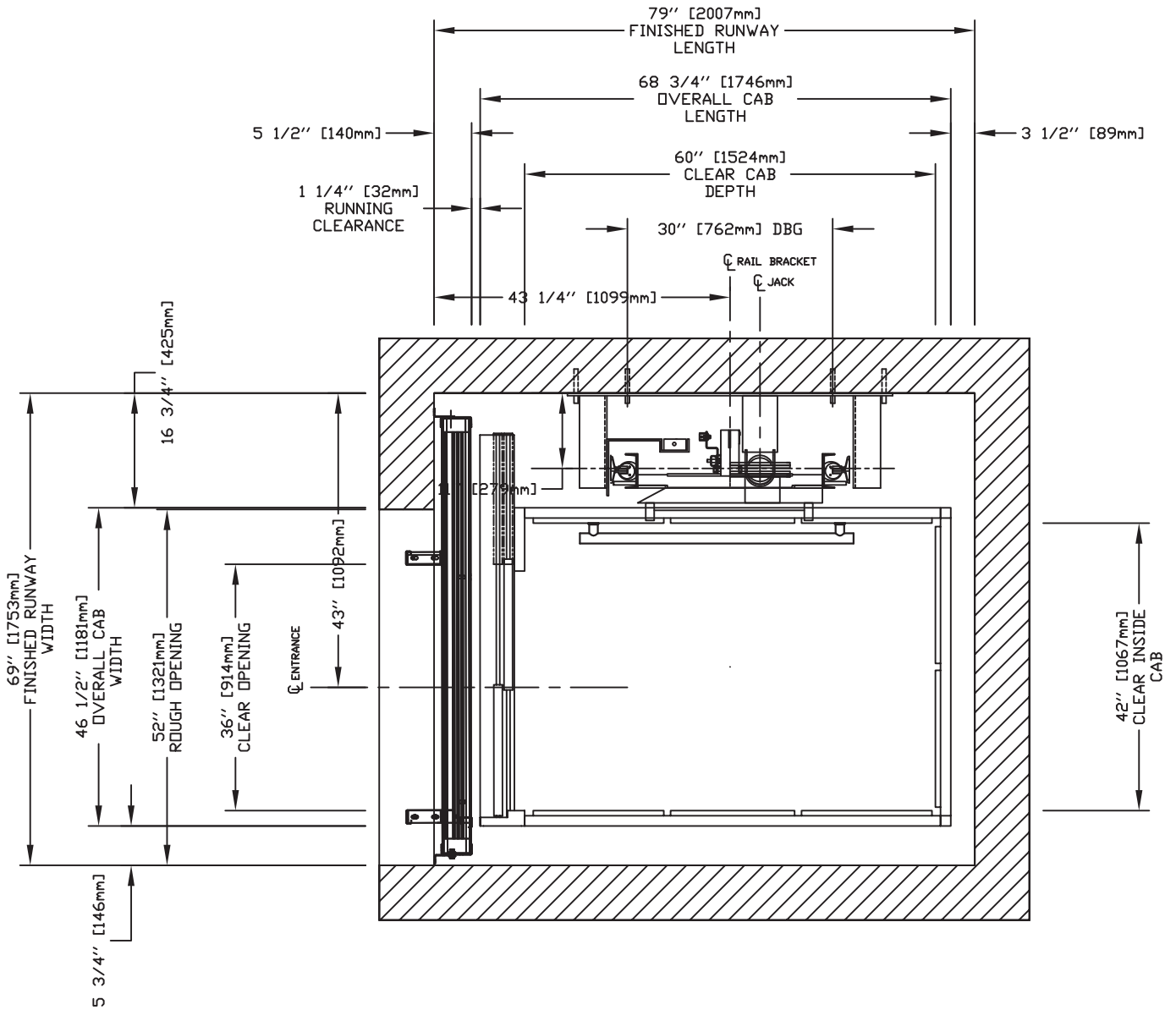



Figure 13: Type 1 - 42" x 60" with 2 Speed Doors

Orion 42" x 60" Type 2 with 2 Speed Door

NOTICE
 For Masonry or Drywall Entrance Details, refer to the drawings on pages 30-33. The cab dimensions provided in this manual are based on a PLAM cab.

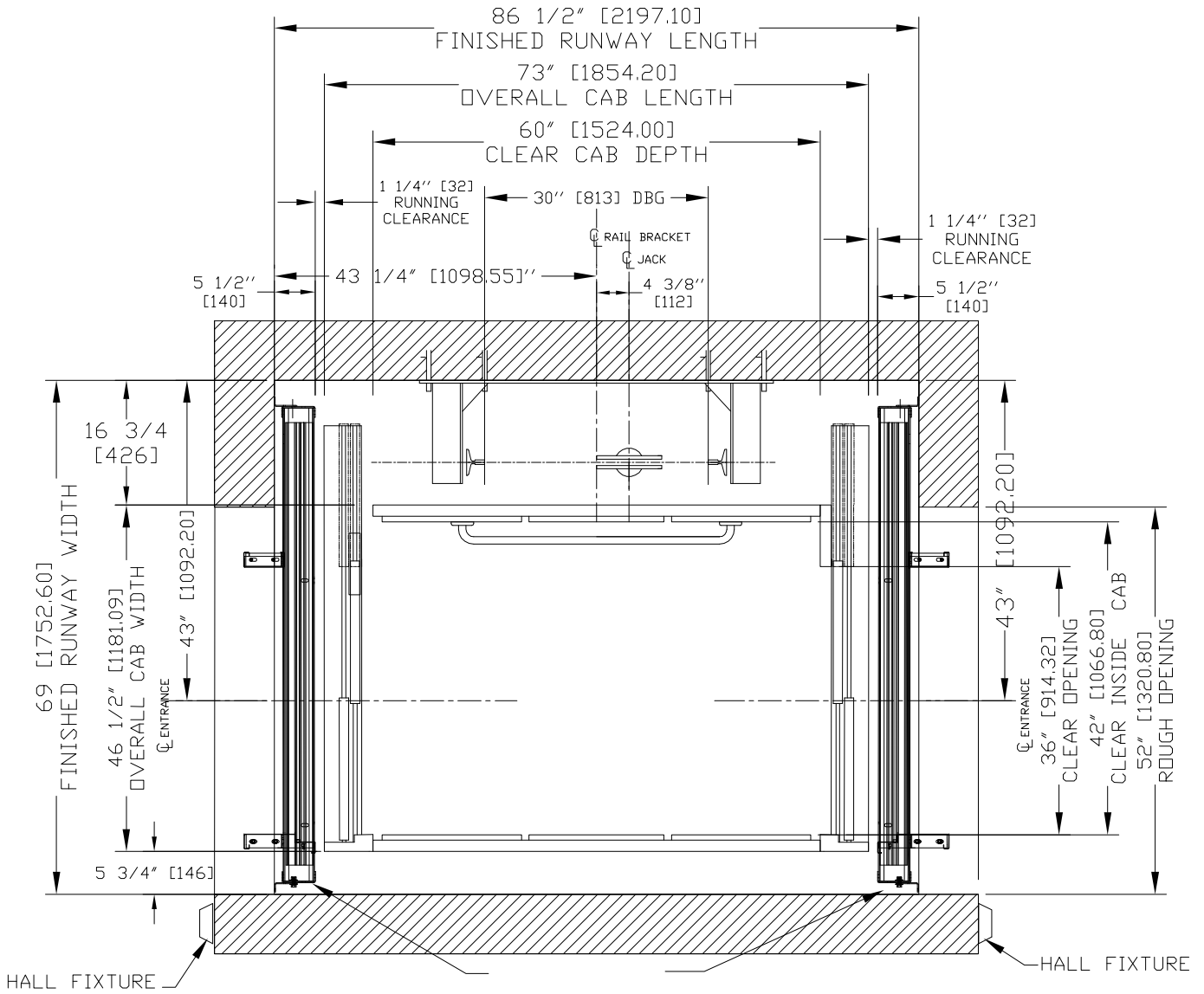



Figure 14: Type 2 - 42" x 60" with 2 Speed Doors

Orion17 - 48" x 54" Type 1 with 2 Speed Door

NOTICE
 Plan view drawing can be reversed for Right Hand applications.
 For Masonry or Drywall Entrance Details, refer to the drawings on pages 30-33.
 The cab dimensions provided in this manual are based on a PLAM cab.

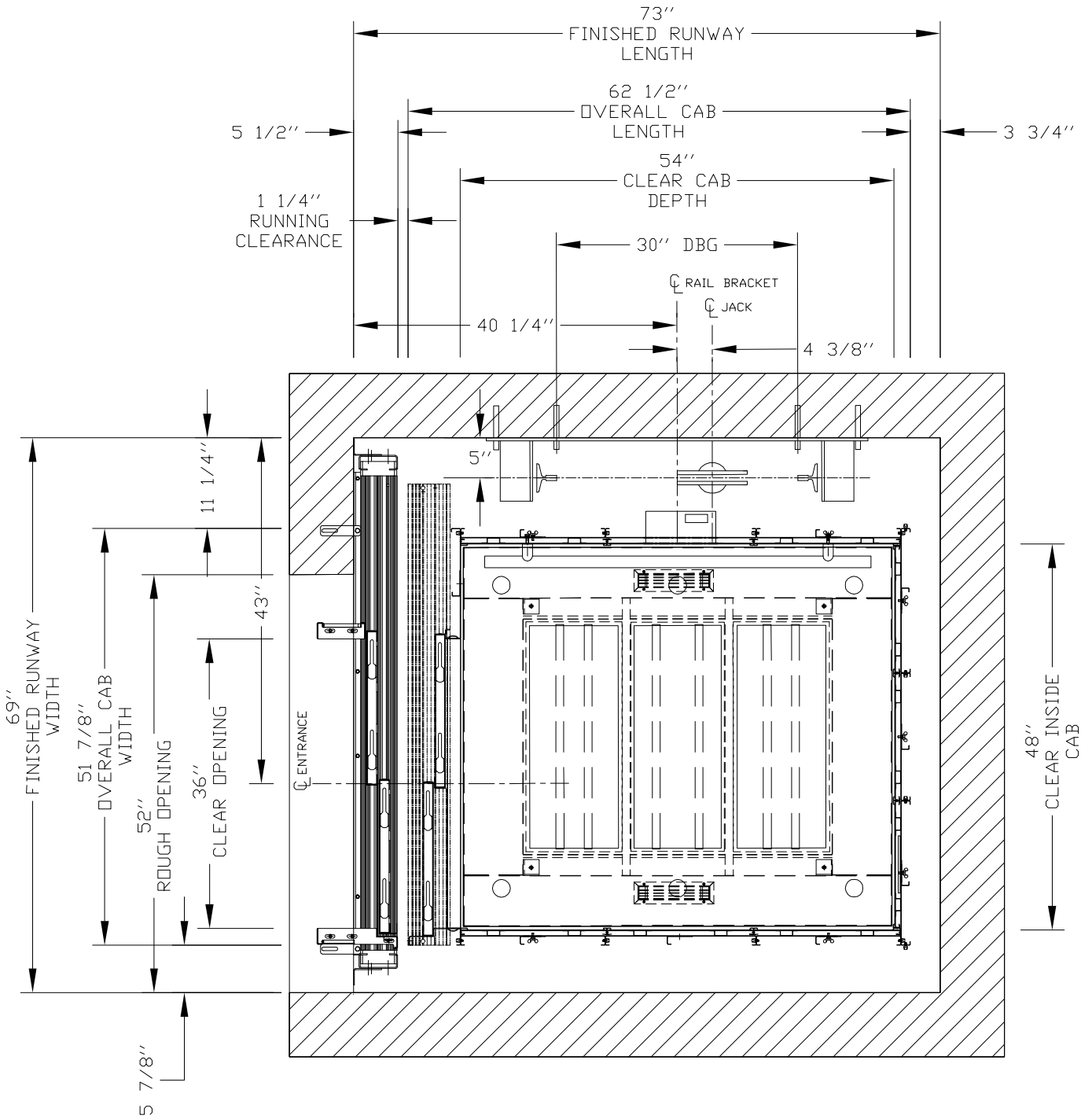



Figure 15: Orion17 Type 1- 48" x 54" with 2 Speed Doors

Orion17 - 48" x 54" Type 2 with 2 Speed Door

NOTICE
 For Masonry or Drywall Entrance Details, refer to the drawings on pages 30-33. The cab dimensions provided in this manual are based on a PLAM cab.

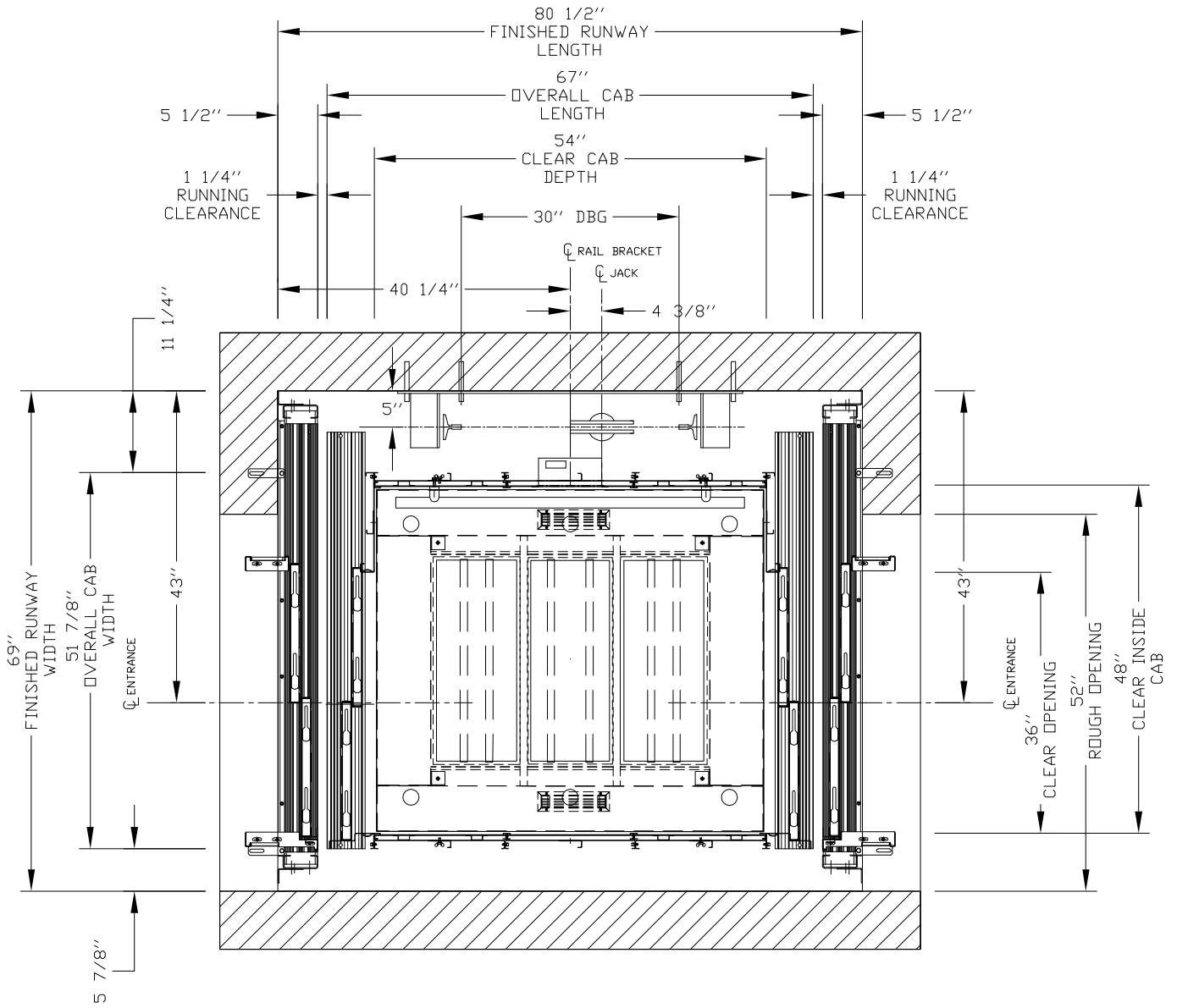



Figure 16: Orion17 Type 2- 48" x 54" with 2 Speed Doors

Orion17 - 42" x 60" Type 1 with 2 Speed Door

NOTICE
 Plan view drawing can be reversed for Right Hand applications.
 For Masonry or Drywall Entrance Details, refer to the drawings on pages 30-33.
 The cab dimensions provided in this manual are based on a PLAM cab.

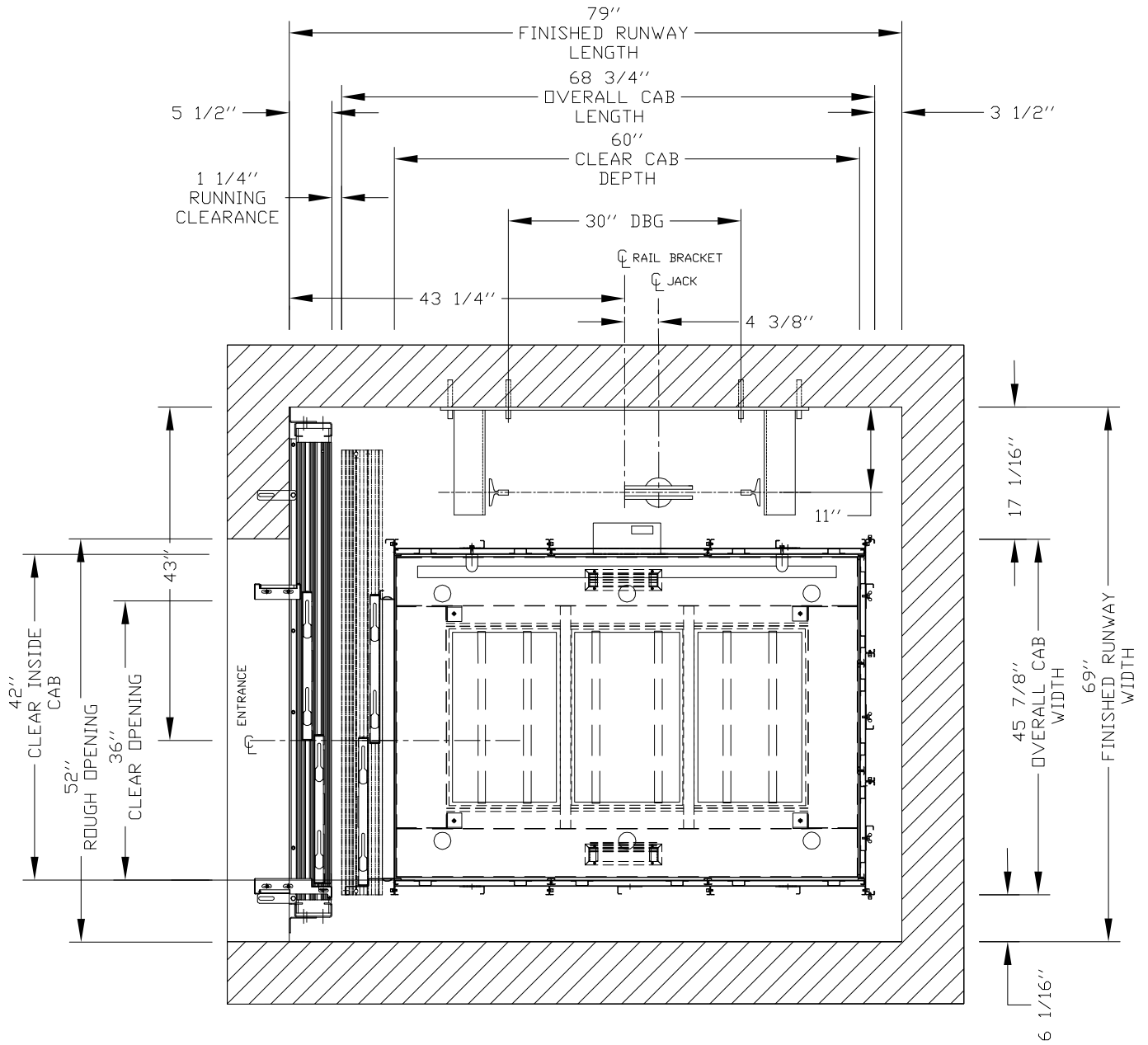

Figure 17: Orion17 Type 1 - 42" x 60" with 2 Speed Doors

Orion17 - 42" x 60" Type 2 with 2 Speed Door



NOTICE

For Masonry or Drywall Entrance Details, refer to the drawings on pages 30-33. The cab dimensions provided in this manual are based on a PLAM cab.

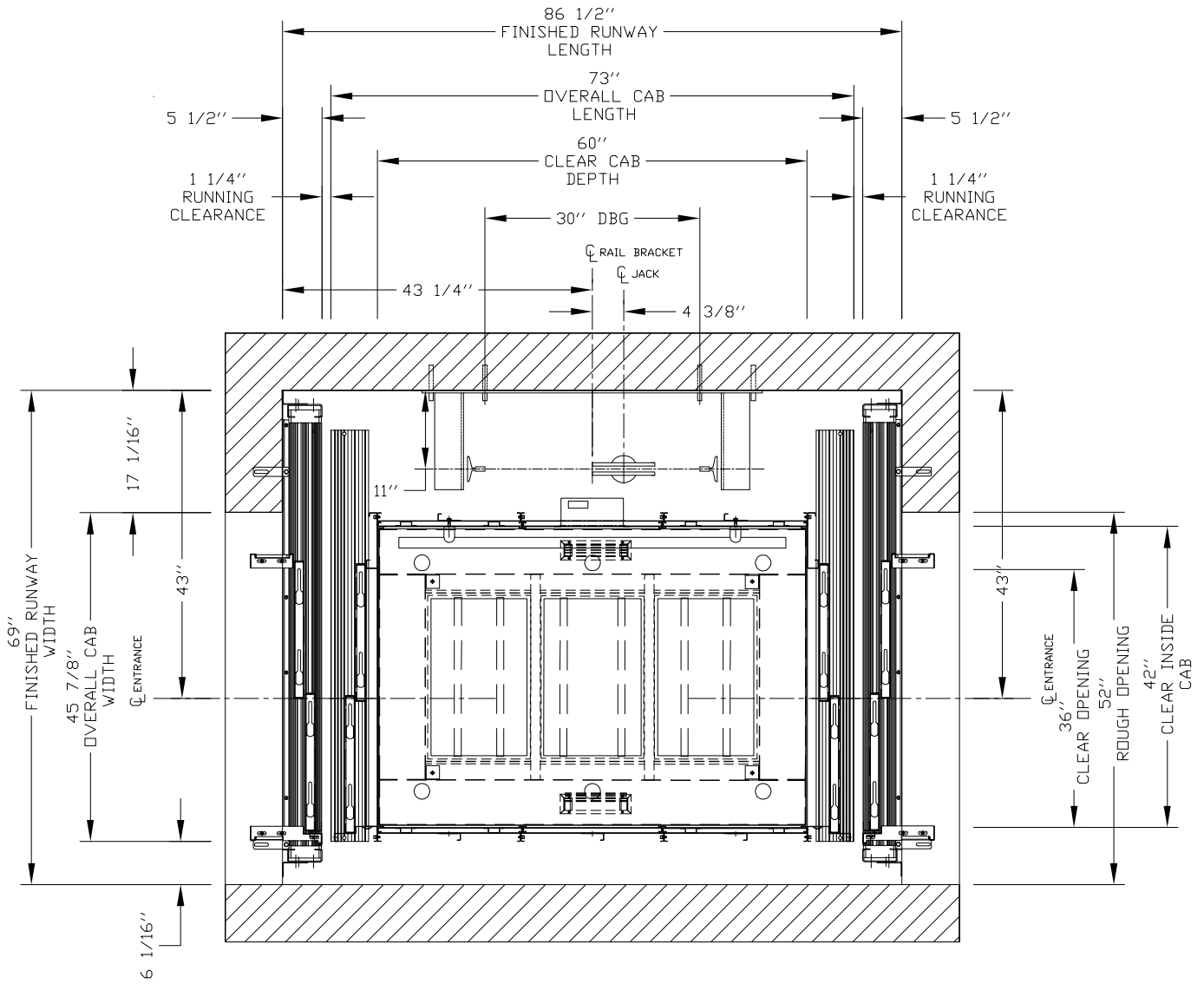

Figure 18: Orion17 Type 2 - 42" x 60" with 2 Speed Doors

Loads on Building and Pit Loading

Seismic zones 0 and 1		Seismic zone 2		Seismic zone 3 or greater	
RAIL FORCES		RAIL FORCES		RAIL FORCES	
*R1	*R2	*R1	*R2	*R1	*R2
720 lbf	260 lbf	1200 lbf	300 lbf	2400 lbf	400 lbf
RAIL WEIGHT : 8.0 lbs / ft		RAIL WEIGHT : 8.0 lbs / ft		RAIL WEIGHT : 8.0 lbs / ft	

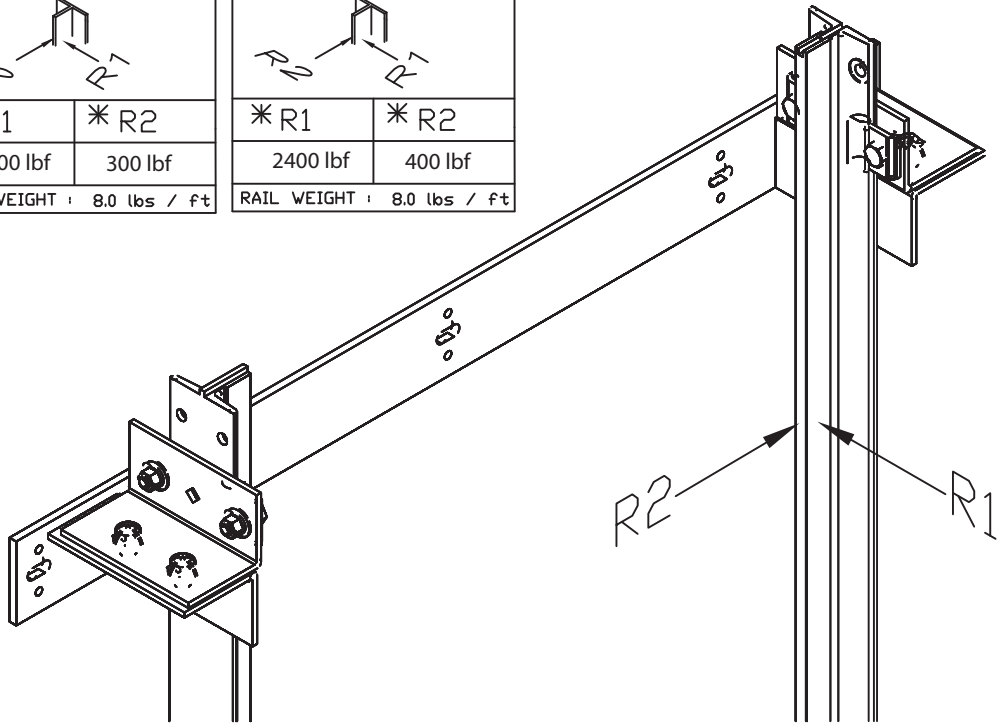

Figure 19: Type 2

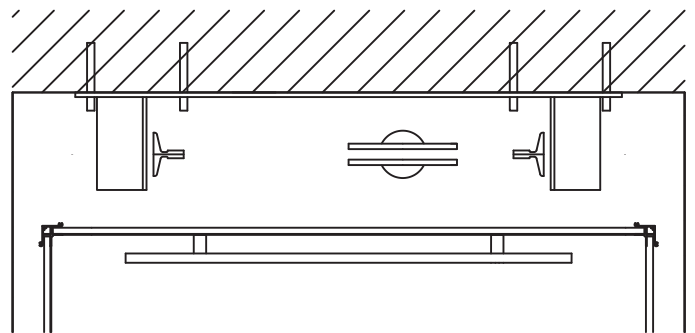
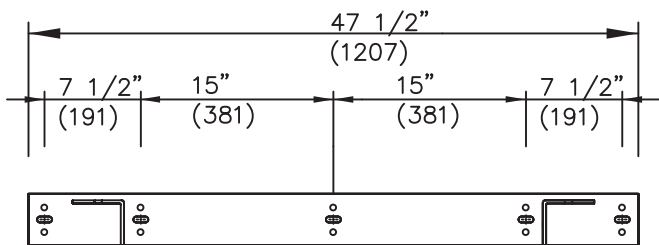
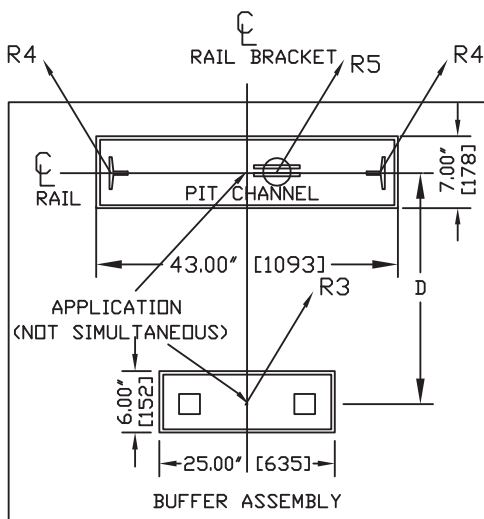

Figure 20: Rail Bracket Dimensions and Support Wall Orientation



CAB WIDTH	DIST (D)
42"	31.625"
48"	31.625"
51"	31.625"
54"	31.625"

R3 - Condition I:
When fully loaded car hits buffer (bumper).

R4 - Condition II:
When safeties engage on rails with 110% loaded car at governor tripping speed.

R5 - Condition III:
Normal running with 1.2 times impact for starting and stopping jerks.

PIT PRE-ACTION FORCE	
R3	8000 LBS
R4	3000 LBS
R5	9000 LBS

Figure 21: Floor liner minimal clearance

Rail Support Wall Structure

NOTICE
Building structural engineer to assure that building and shaft will safely support all loads imposed by the elevator equipment.
Check Seismic Zone to see if the structure is allowed by your local building codes

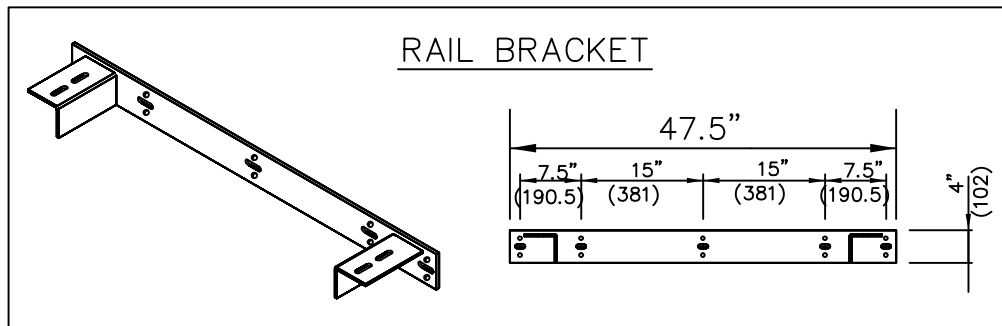
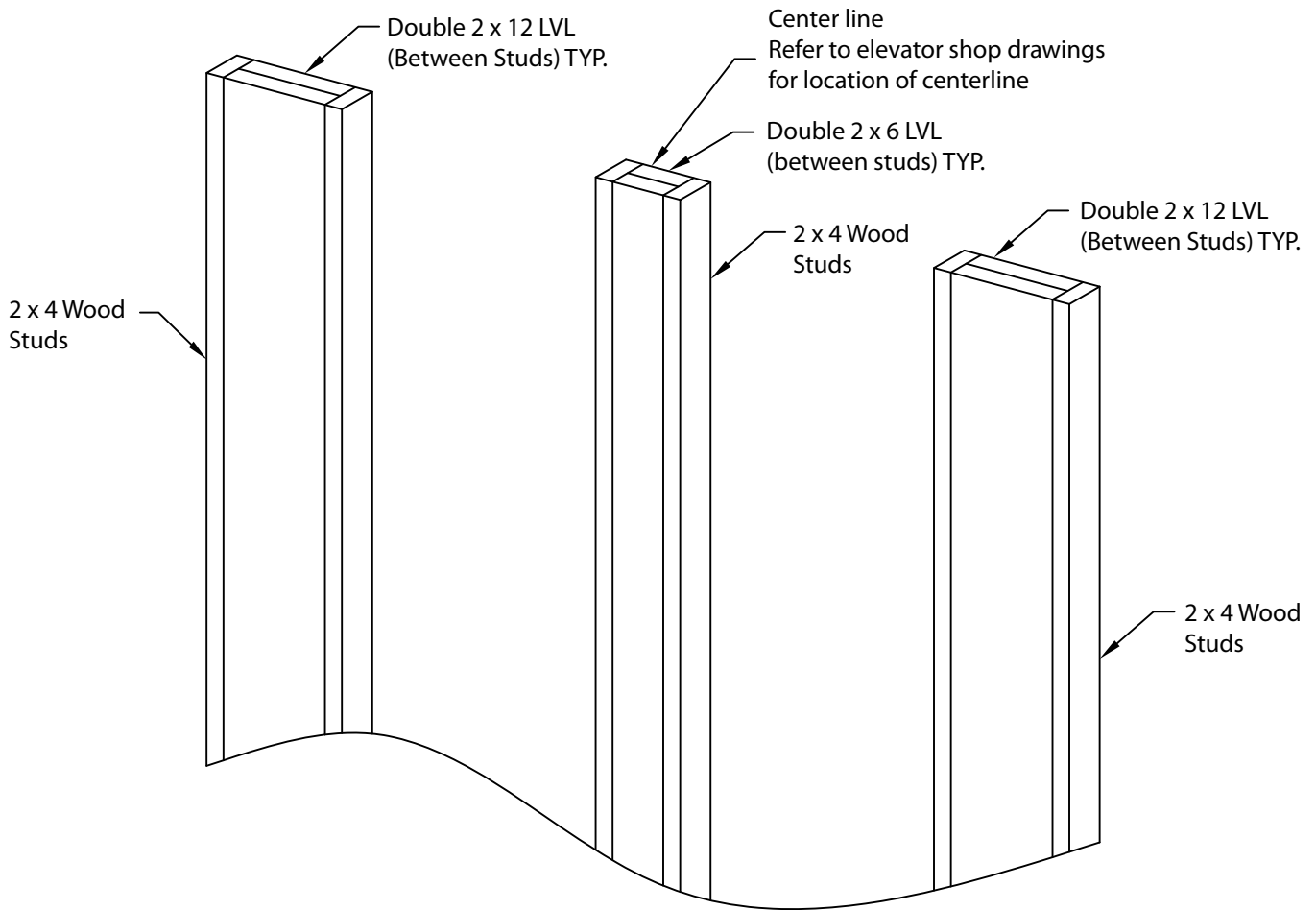

Figure 22: Elevation view - 2000 mm (78 3/4") cab

Rail Support Wall Top View

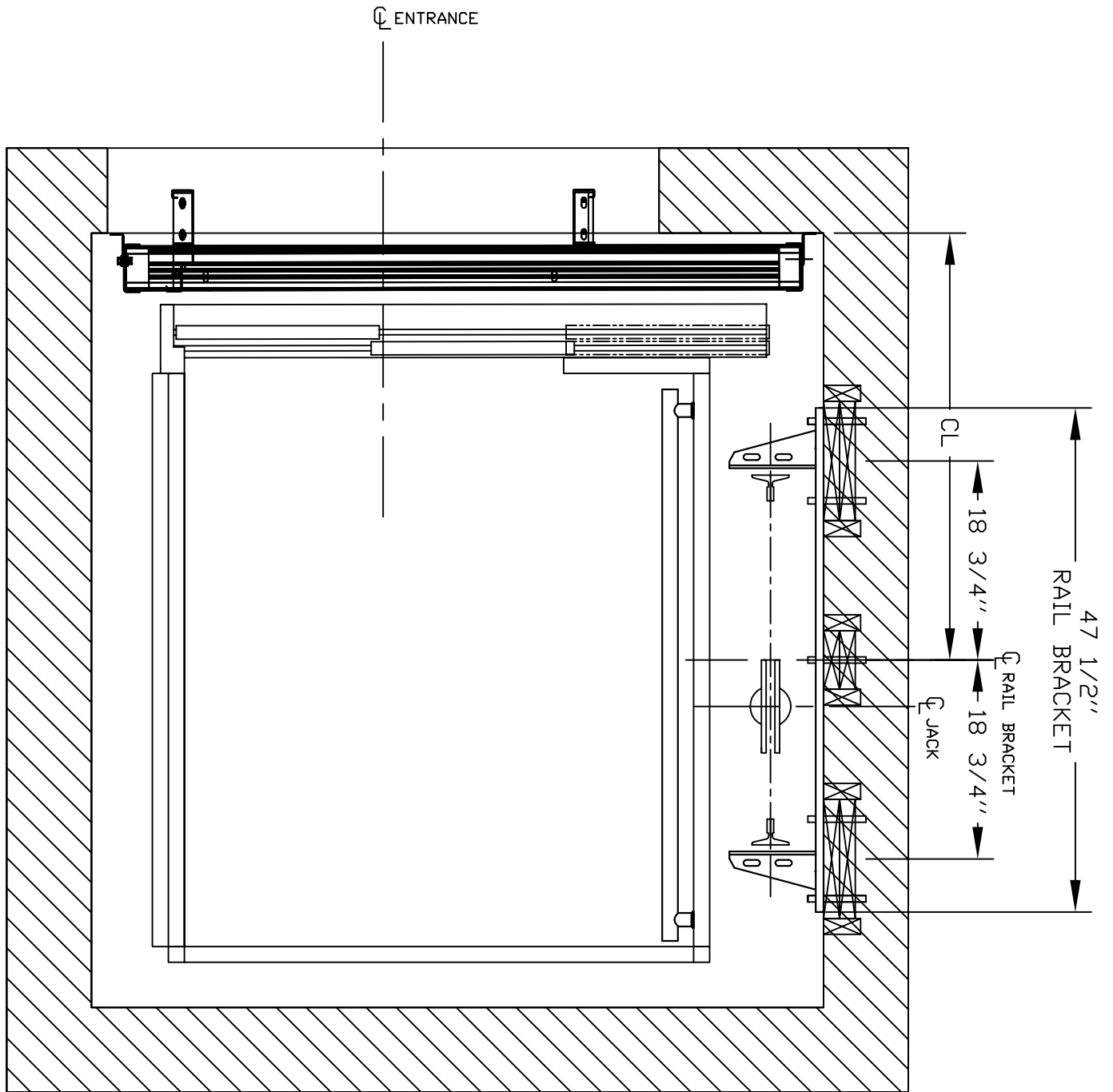

Figure 23: Elevation view - 2000 mm (78 3/4") cab

Big Rail Bracket Backing



NOTICE

If the installation calls for horizontal bracing or the extended rail brackets, make sure there is sufficient support that extends the full height of the rail bracket back plate including the extended leaf supports.

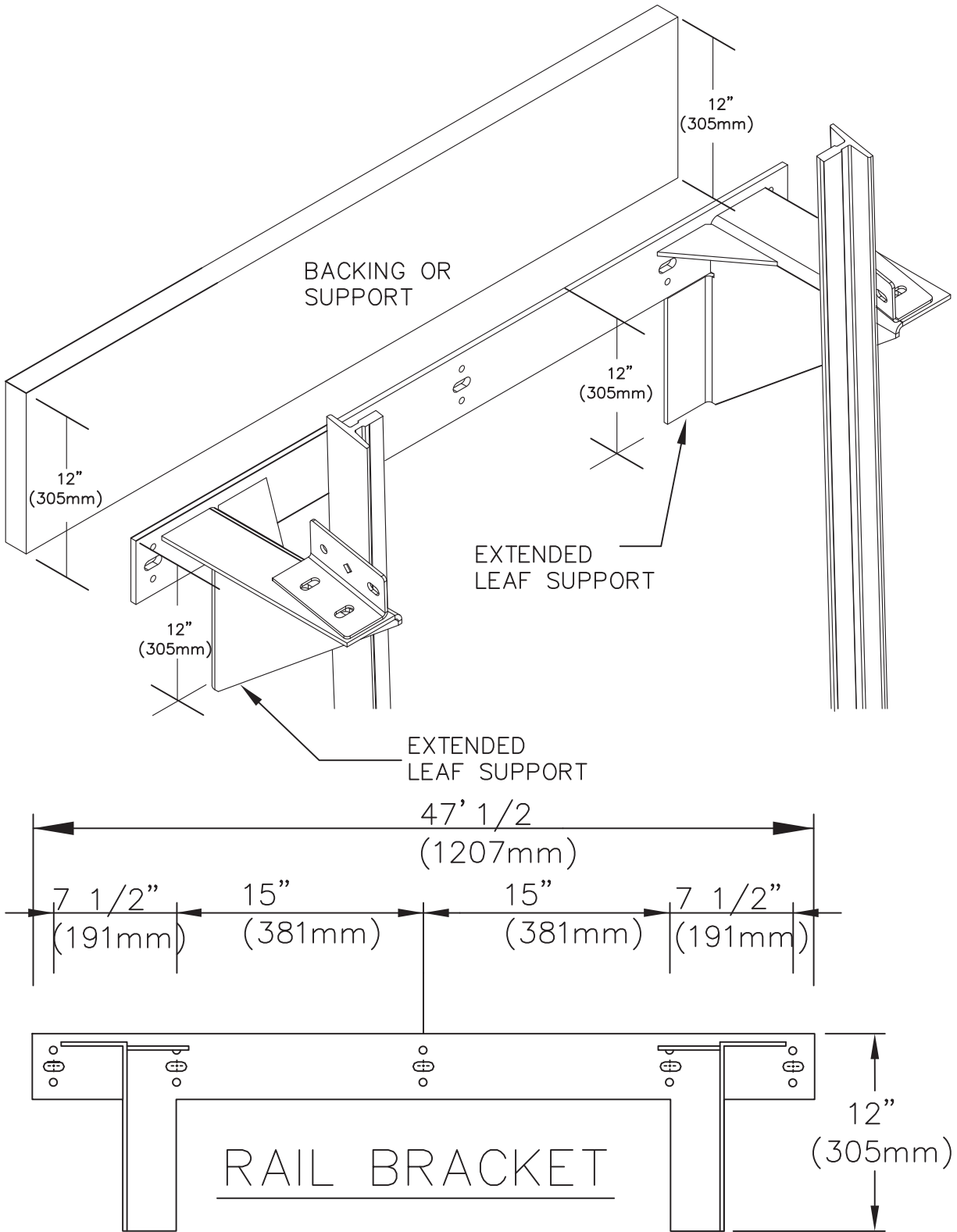

Figure 24: Elevation view - 2000 mm (78 3/4") cab

Entrance Mounting Details for 2 Speed Doors with Drywall Construction

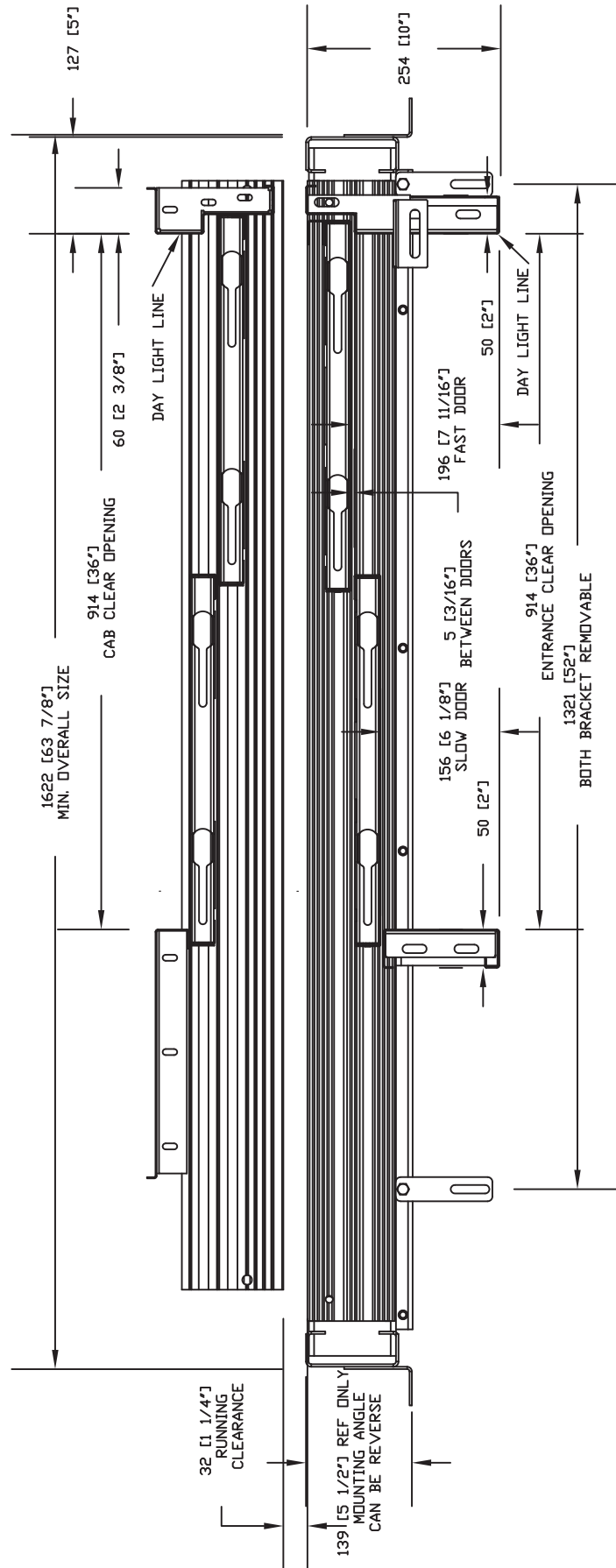
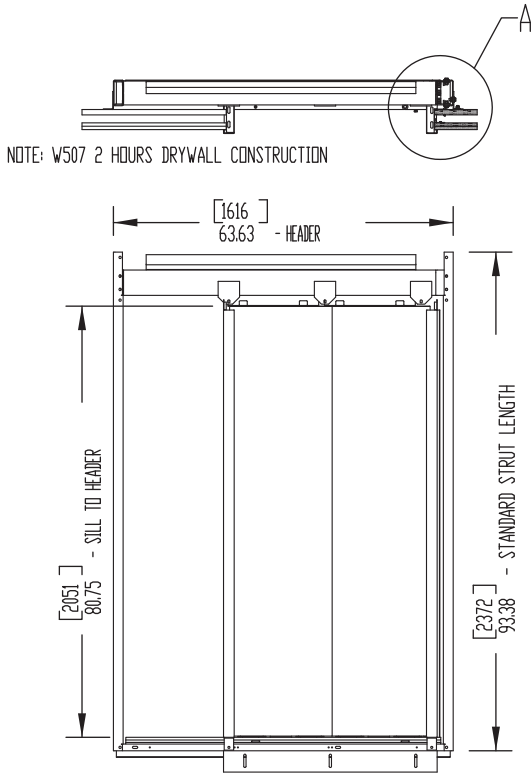

Figure 25: Drywall Construction

Entrance Mounting Details for 2 Speed Doors with Drywall Construction

NOTICE

Interface between entrance frame assembly and wall structure as per wall design.
 No. W 507 For Non-bearing wall installation instructions.
 Entrance Frame Assembly is not designed to bear overhead loads. Contractor to provide adequate wall structure support.



ENTRANCE LOADS ON BUILDING
 RH = 5000 N (1125 lbf)
 RVD = 1550 N (350 lbf)
 RVU = 1000 N (225 lbf)
 PER SECTION 2.11.11.8.

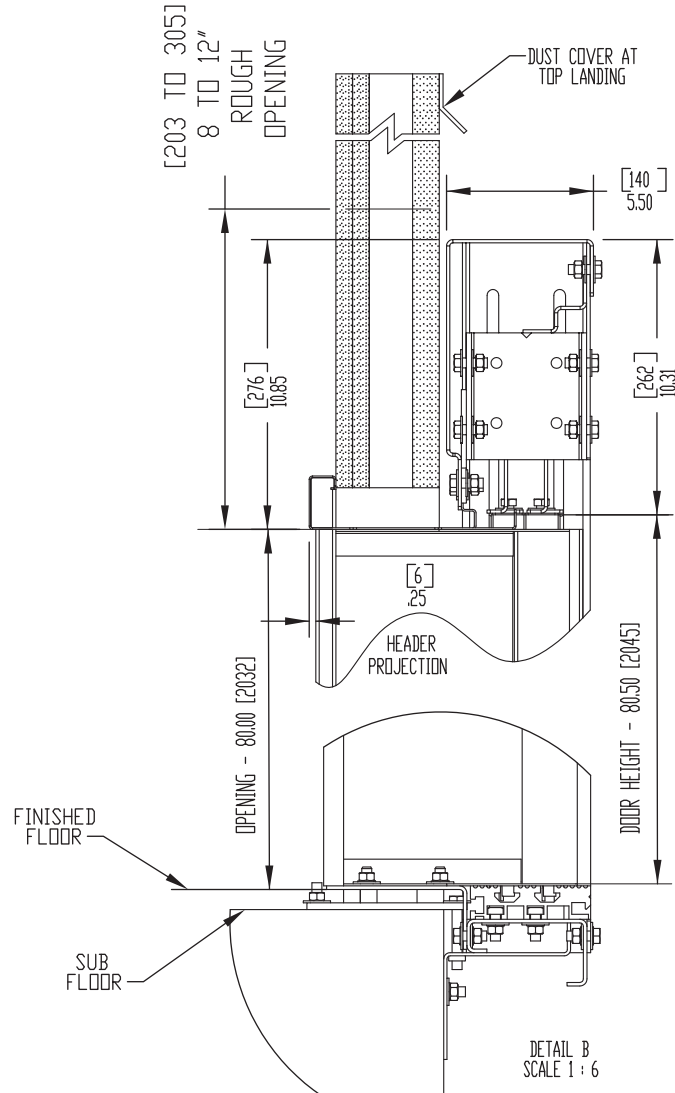
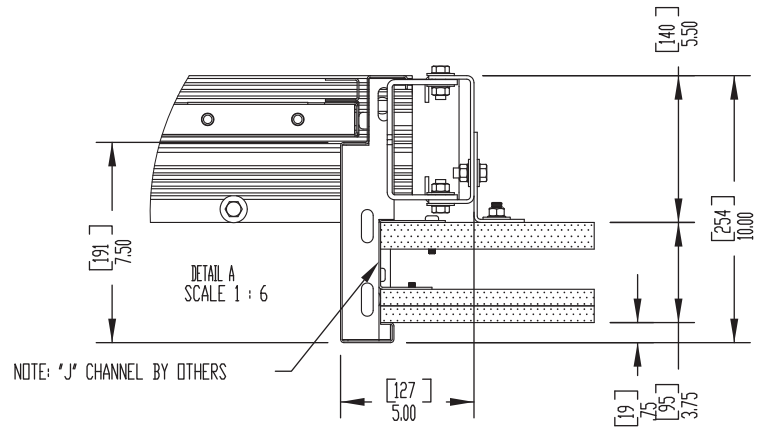
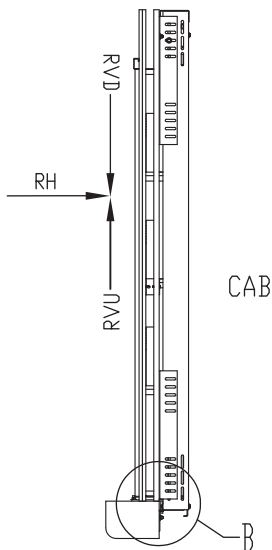

Figure 26: Drywall Construction

Entrance Mounting Details for 2 Speed Doors with Masonry Construction

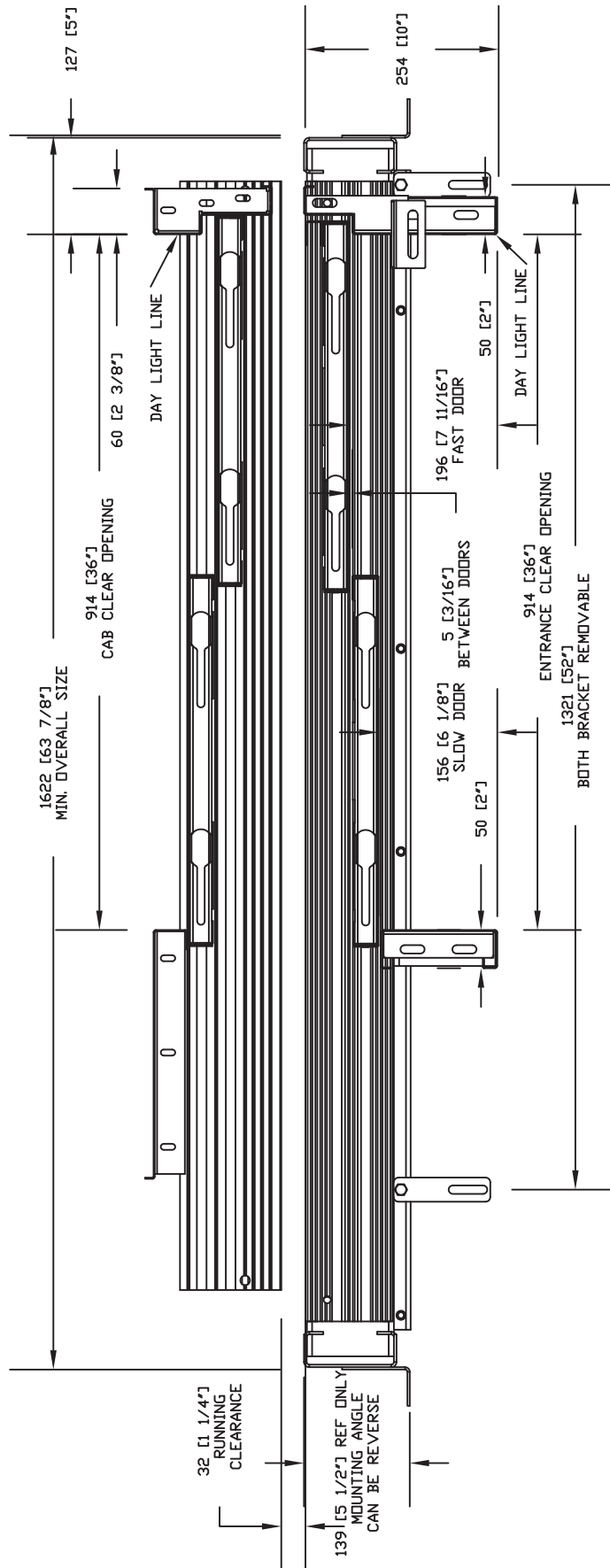

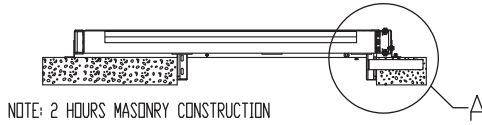

Figure 27: Masonry Construction

Entrance Mounting Details for 2 Speed Doors with Masonry Construction

NOTICE
 Interface between entrance frame assembly and wall structure as per wall design.
 No. W 507 For Non-bearing wall installation instructions.
 Entrance Frame Assembly is not designed to bear overhead loads. Contractor to provide adequate wall structure support.



NOTE: 2 HOURS MASONRY CONSTRUCTION

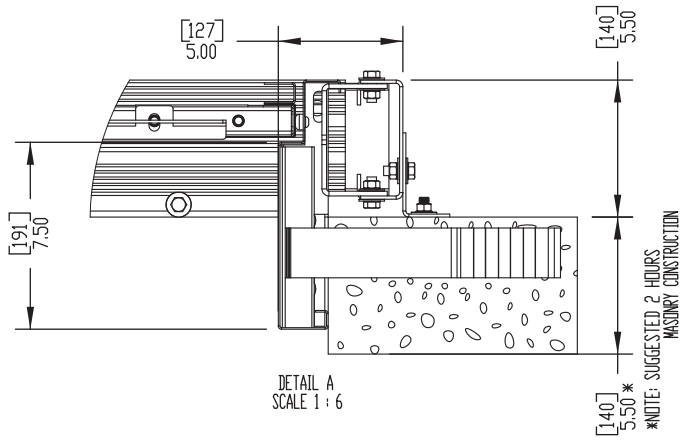
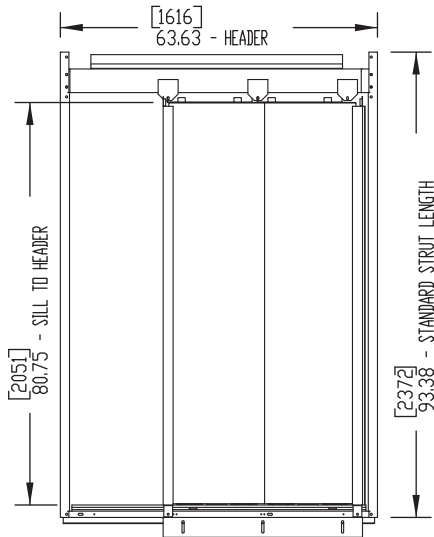

ENTRANCE LOADS ON BUILDING
 RH = 5000 N (1125 lbf)
 RVD = 1550 N (350 lbf)
 RVU = 1000 N (225 lbf)
 PER SECTION 2.11.11.8.

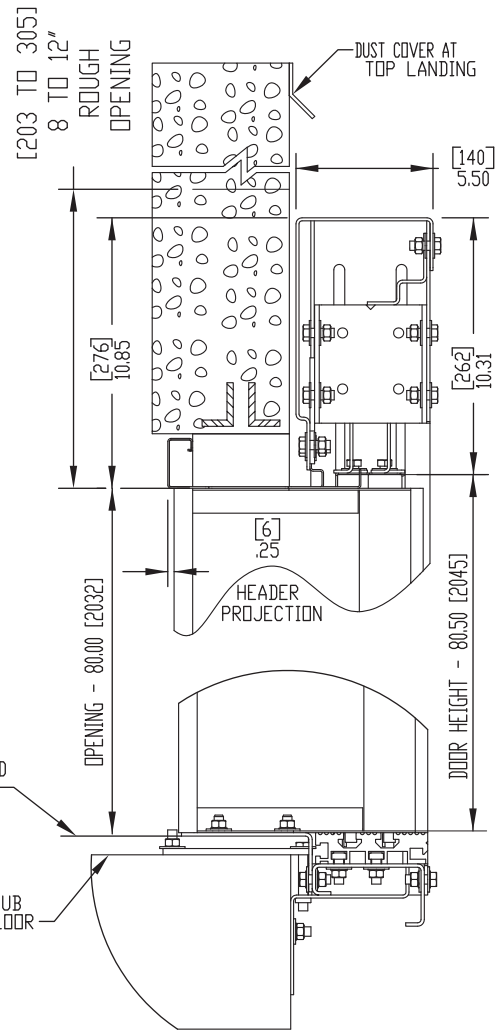
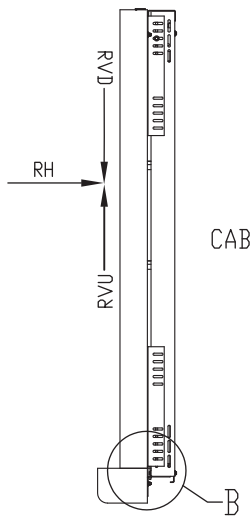

Figure 28: Masonry Construction

2 Speed Automatic Door and Guide Rail Information



NOTICE

See Hoistway requirements for the location of the door centerline.
 Door Panels and frame are primed for painting.
 For Metric equivalents: Inches x 25.4 = x mm

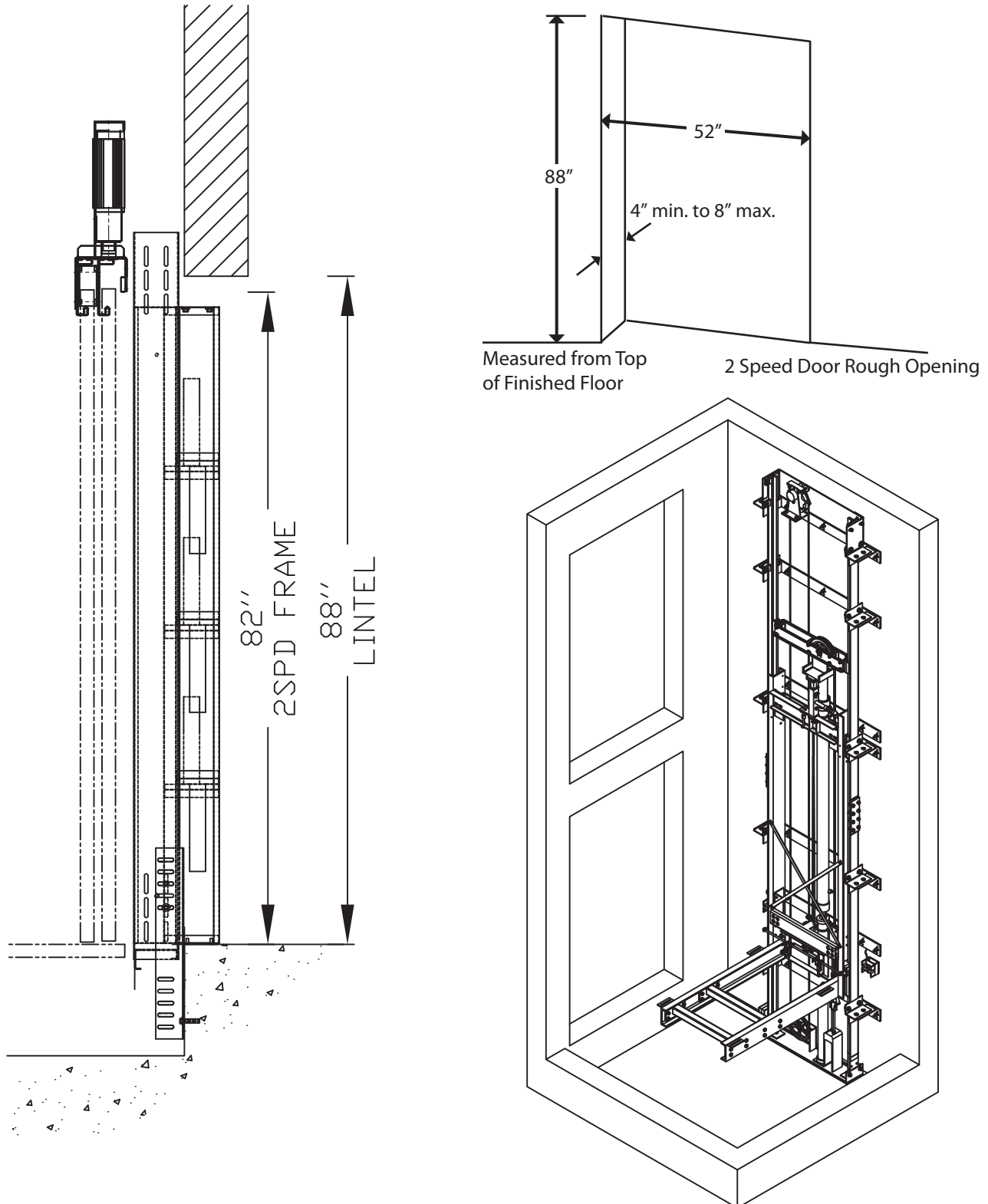

Figure 29: Elevation view - 2000 mm (78 3/4") cab

Pit and Overhead Clearance

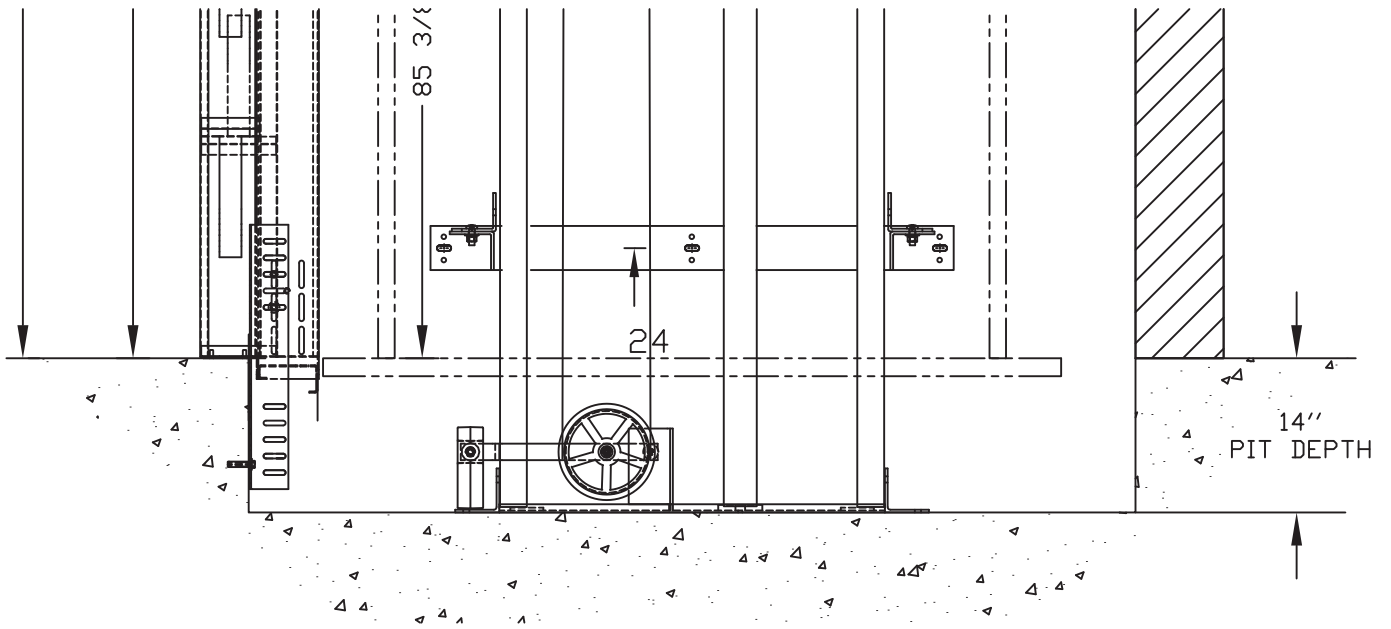

Figure 30: Orion Pit Depth

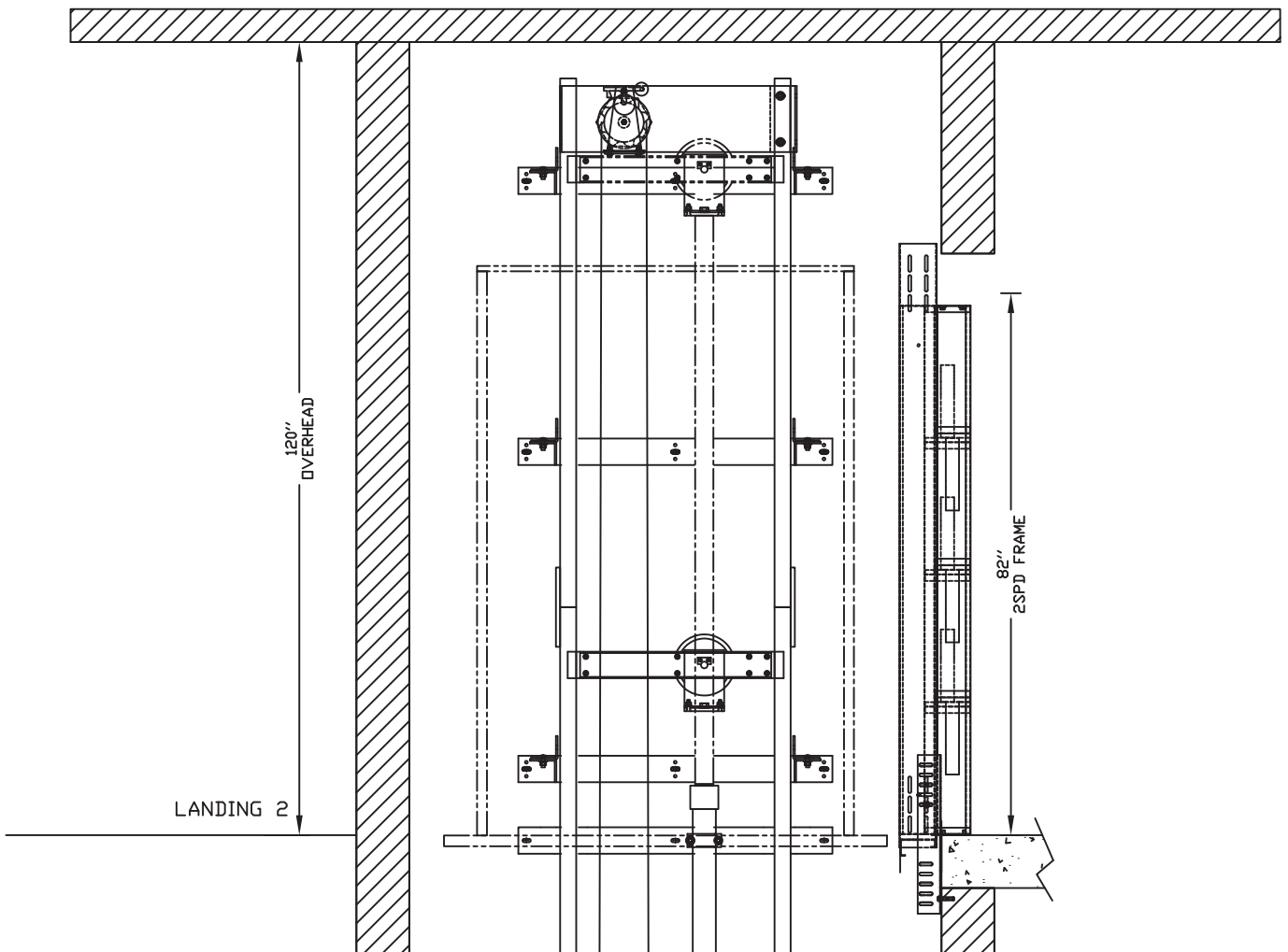

Figure 31: Orion Overhead

SPECIFICATIONS FOR PART 5.3 COMPLAINT

PART 1 GENERAL

1.1 SUMMARY

A. The product described herein, manufactured by Savaria is an elevator designed and dimensioned to provide Limited Use/Limited Application (LULA) elevator to suit individual building requirements for use by persons with disabilities.

1.2 REFERENCES

A. Elevator shall be designed, manufactured and installed in accordance with the following standards:

- 1 American National Standards Institute (ANSI).
- 2 American Society of Mechanical Engineers (ASME).
- 3 National Electrical Code (NEC) Canadian Electrical Code (CEC)
- 4 American Society for Testing Materials (ASTM).
- 5 American Welding Society (AWS). Canadian Welding Bureau (CWB)

1.3 SYSTEM DESCRIPTION

A. 5 hp submersed motor and pump with electronic proportional valve assembly; Programmable logic controller with collective operation; 1:2 roped hydraulic single stage cylinder with line rupture valve.

B. Number of Stops: (specify:) Two to Four.

C. Car Configuration: (specify:) straight-thru, 90° side exit or enter/exit same side.

D. Maximum Travel: (specify:) Up to 25' (7.62 m)

E. Rated Load: (specify:) 1400 lbs. (635 kg)

F. Rated Speed: 30 fpm (.15m/s)

G. Car Size:

- 1 48" x 54" (1219 mm x 1372 mm) platform (standard)
- 2 84" (2134 mm) high ceiling

H. Car Walls: (specify:) Steel panels (black or architectural white) with (optional) raised plastic laminate panels (contact Savaria for colors).

I. Car Ceiling: White panel.

J. Car Lighting: Four recessed lights.

K. Operating Features:

- 1 Car Operating Panel: (specify:) Brushed stainless steel or brushed brass panel with illuminated automatic controls, keyed light switch, emergency stop switch and alarm button
 - 2 Hall Stations: (specify:) Brushed stainless steel or brushed brass panel with illuminated button and (specify option:) key lock provided at each landing.
 - 3 Car Door(s): Fully automatic, side opening, sliding car door with electromechanical interlocks, obstruction sensor, and automatic re-open system.
 - 4 Hoistway Doors: 1 ½ hour fire rated fully automatic side opening, sliding hoistway doors with two side opening panels in steel frame with electromechanical interlocks.
 - 5 Handrail: (specify:) Stainless steel or brass.
 - 6 Pit Switch
 - 7 Car top inspection station with UP and DOWN test switches, emergency stop, light outlet
 - 8 Automatic homing to the lowest floor (optional)
 - 9 Slack rope safety.
 - 10 Anti-creep device.
 - 11 Overspeed governor (may not be required) – consult AHJ
 - 12 Dual direction leveling.
- Upper and lower terminal limit.
 - Pump run timer.

- Pit clearance device (where required)
- Automatic battery powered and manual emergency lowering control devices.
- Minimum pressure switch.
- Maintenance stop blocks.
- (specify option:) Fire Fighters Service (available).
- (specify option:) Hall lanterns with chime.
- (specify option:) Recessed telephone cabinet (brushed stainless steel or brushed brass).
- (specify option:) Buffer springs (requires 24" pit).

1.4 QUALITY ASSURANCE

- A. Manufacturer: Provide elevator manufactured by a firm with a minimum of 10 years experience in fabrication of elevators equivalent to those specified.
- B. All designs, clearances, workmanship and material, unless specifically accepted, shall be in accordance with all codes having legal jurisdiction.
- C. All load ratings and safety factors shall meet or exceed those specified by all governing agencies with jurisdiction and shall be certified by a professional engineer.
- D. Elevator shall be subject to applicable state, local and city approval prior to installation and subject to inspection after installation. Determination of and adherence to these regulations is the responsibility of the elevator contractor.
- E. Welders certified in accordance with requirements of AWS D1.1 or CWB shall perform all welding of all parts.
- F. Substitutions: No substitutions permitted.

1.5 WARRANTY

- A. Warranty: Manufacturer shall warrant component parts of the Orion elevator for a period of 36 months from shipping date. This warranty only applies to products installed and maintained by a Savaria Authorized Dealer in conformance with all applicable local and national codes. The warranty is void if regular inspection and maintenance of product is not being carried out by an Authorized Savaria Dealer in accordance with the recommendations contained in the Owner's Manual. It is the Owner's responsibility to keep records of all such service.

PART 2 PRODUCT

2.1 MANUFACTURER

Provide the Orion Commercial LU/LA Elevator manufactured by Savaria.

Toll Free Number (800) 661-5112

Phone (905) 791-5555

Fax (905) 791-2222

Web site: <http://www.savaria.com>

2.2 MATERIAL

- Guide Rail: Dual 8 lbs./ft. machined steel T-rail system.
- Wire Rope: Two 3/8" diameter 7 x 19 ga. IWRC aircraft cables with rope wedge sockets.
- Sling: Structural and formed steel plates with guide shoes.
- Platform Floor: Unfinished plywood flooring.

2.3 FINISHES

A. Components shall be prepared with

- 1 Pre-treatment,
- 2 Alkaline detergent wash,
- 3 Clear water rinse,
- 4 Iron phosphate coating,
- 5 Clear water rinse and finished with electrostatically applied and baked thermostatic powder coat finish. Standard color is architectural white.

2.4 ELECTRICAL SYSTEMS

A. The electrical contractors shall provide:

- 1 208V three phase 30 AMP 60 Hz or 230 V single phase 40 AMP 60 Hz source in the machine area with manually operated fused line disconnect.
- 2 120 VAC, single phase, 15 amp, 60 Hz, single phase power source with manually operated fused line disconnect for car lighting and a light outlet inside the hoistway.
- 3 Telephone circuit in the machine area.

PART 3 EXECUTION

3.1 ACCEPTABLE INSTALLERS

- A. Installers shall be experienced in performing work of this section who have specialized in work comparable to that required for this project.
- B. Installers shall be certified and trained by the manufacturer.

3.2 EXAMINATION

- A. Use field dimensions and approved manufacturer's shop drawings to examine substrates, supports and other conditions under which this work is to be performed. Do not proceed with work until unsatisfactory conditions are corrected.

3.3 INSTALLATION

- A. The Orion elevator shall be installed in accordance with manufacturer's instructions and as specified and approved by architect.

3.4 DEMONSTRATION

- A. The elevator contractor shall make a final check of the elevator's operation with the Owner or Owner's representative present prior to turning the elevator over for use. The elevator contractor shall determine that operating and safety devices are functioning properly.

END OF SECTION

Intent of specification is to broadly outline equipment required but does not cover details of design and construction. Dimensions and specifications are subject to constant change and continually evolving codes and product applications. For additional technical information, contact Savaria at (800) 661-5112 or www.savaria.com.

Orion

Commercial Elevator PLANNING GUIDE

Part No. 000682, Rev. 045
17-m03-2026

Copyright © 2025

Savaria Concord Lifts, Inc.
www.savaria.com

Sales
2 Walker Drive
Brampton, Ontario L6T 5E1
Canada
Tel: (905) 791-5555
Fax: (905) 791-2222
Toll Free: 1-800-661-5112

