

Savaria® Luma

Through-floor lift

Beautiful access lives with the Savaria Luma through-floor lift

Like a home elevator, but without the need for a shaftway, the Luma lift provides easy two-level service for your home. Finely finished with a luxury feel and panoramic views, the Luma Lift is proudly designed and built by Savaria, a world leader in accessibility products.



Make Your Steps Effortless

The Luma lift fits easily into your home with its self-supporting rails and concealed quiet drive system. The fully enclosed cabin with crystal clear acrylic panels, elegant lighting system and neutral white finish makes Luma feel spacious and at home in virtually any décor.

Modern simple design

Designed for simplicity, the Luma lift is easy to use with large, backlit buttons. Get peace of mind with included Savaria Link wi-fi monitoring by your local dealer, as well as our One Touch Alert system and in-cabin status panel.

Fast and flexible installation

Installation can be completed in just a one or two days. Construction preparation generally requires a simple floor cut-out and floor bracing. A self-supporting rail system and compact footprint gives the Luma Lift floorplan flexibility. Tuck into a corner, or place it anywhere in the room.

Safety

Savaria takes pride that the Luma Lift meets all safety code standards. This includes a fully enclosed cabin equipped with door interlock to eliminate any safety hazards. A safety pan sensor system stops the lift should it meet any obstruction in either direction.

Easy Access

A stylish non-skid floor with sloped threshold allows for easy access without the need for a pit or ramp. Luma features a full-sized door while a second door can be added to provide straight-through access to accommodate your home's floorplan.

Efficiently powered

Luma is battery-powered and can operate both up and down for as many as five trips during a power outage. The winding drum drive is quiet and inexpensive to run on standard household power.



Sloped threshold and attractive non-skid flooring



Handrail and full height acrylic panels



Self-supporting rails with tucked-away cable system



Simple, intuitive operation with in-cabin lift status LCD panel

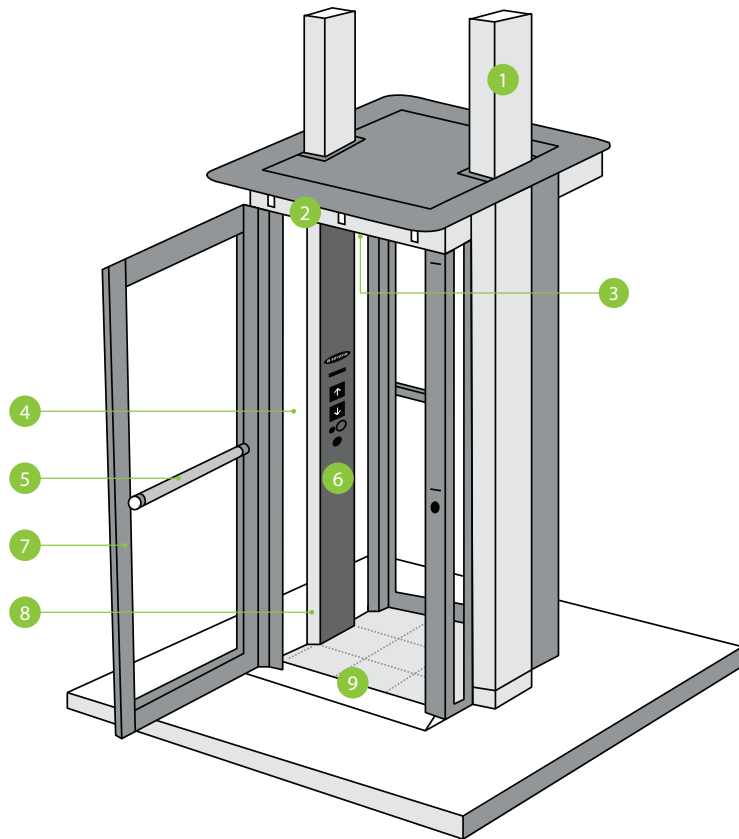

Luma Lift Features

- Self-supporting rails with tucked-away cable system
- Ceiling trim and car top cap
- Ventilation fan
- Full-sized clear panels
- Full width handrail
- Illuminated buttons and lift status panel
- Full-sized door
- Recessed lighting in door and cab panels
- Non-skid floor and sloped entrance

Specifications

Capacity	400 lb (181 kg)
Cabin size	29.1"W x 27.8"L* x 78.7"H (739 mm x 706 mm x 2000 mm)
Floor cut-out	46.7"W x 37.6"L (956 mm x 1186 mm)
Maximum travel	13.7' (414 cm), 2 stops
Nominal speed	15 ft/min (0.08 m/s)
Drive system	Winding drum, operated with constant pressure buttons
Power supply	110 - 240 VAC, 5 A (max), 50/60 Hz, single phase
Warranty	36 months parts, ask dealer for details
Additional features	Interior lighting, emergency stop and alarm buttons, One Touch Alert system, Savaria Link wi-fi monitoring system, in-cabin lift status panel, nonskid flooring and full width handrail, sensors to stop the unit if it detects an obstruction, overspeed arrestor, door interlock, and two RF remote controls included

*for 2-door option, cab length is 25.6" (651 mm)

Floor Cutout

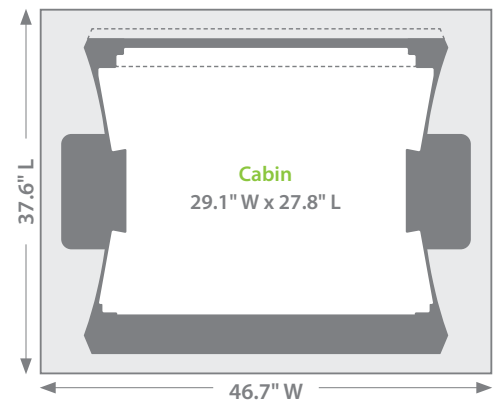

Call us **1.855.728.2742** or visit **Savaria.com** to find your local Luma Lift dealer.

Better mobility for life

Savaria is a global leader in accessibility that designs, engineers and manufactures products to empower personal mobility. We make a complete range of home elevators, stairlifts and commercial accessibility lifts and elevators.